



KATALOG  
NÁBYTKOVÉHO  
KOVÁNÍ

2012



# OBSAH:

<b>KOVÁNÍ</b>	<b>strana</b>
S20/S30 kování pro posuvné skříňové dveře .....	4-5
S25 kování pro skládací dveře .....	6-7
S27 AL/S37 AL kování pro posuvné hliníkové rámy .....	8-9
S34 kování pro posuvné hliníkové rámy .....	10-11
S35 kování pro posuvné skříňové dveře .....	12-13
S36 kování pro posuvné skříňové dveře .....	14-15
S37 kování pro posuvné skříňové dveře .....	16-17
S40/S40H kování pro posuvné skříňové dveře .....	18-19
S45 kování pro posuvné skříňové dveře .....	22-23
S50 kování pro posuvné skříňové dveře .....	24-25
S50N kování pro posuvné skříňové dveře .....	26-27
S55 kování pro posuvné skříňové dveře .....	28-29
S60 kování pro posuvné skříňové dveře .....	30-31
S60N kování pro posuvné skříňové dveře .....	32-33
S60H kování pro posuvné skříňové dveře .....	34-35
S65 kování pro vestavěné skříně .....	36-37
S80/S80SC kování pro interiérové dveře .....	38-39
S100 kování pro interiérové dveře .....	40-41
Softclose .....	42

<b>HLINÍKOVÝ PROGRAM</b>	<b>strana</b>
Hliníkové nábytkové rámečky	43-46
Hliníkové nábytkové nožky	47
Dna S-LED mini	48
Světelné police a světelná dna	49
Hliníkové nábytkové podnože	50-51
Madla a úchytkové profily, narážecí hrany	52-57
Skleněné výplně	58-59

# S20/S30

PRO POSUVNÉ  
SKŘÍŇOVÉ DVEŘE

Spodní vedení  
se zafrézovanou drážkou

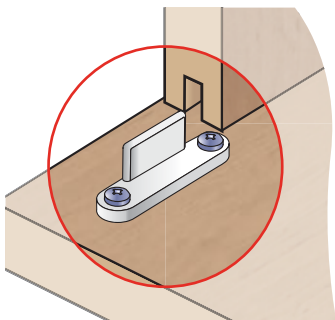

Spodní vedení – profil S03,  
vodítko S35B viz str. 12-13

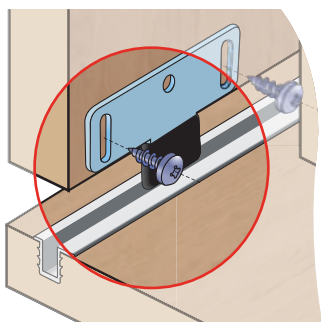

Detail dolního vedení k S30,  
vozíky jsou univerzální  
pro přední i zadní dveře

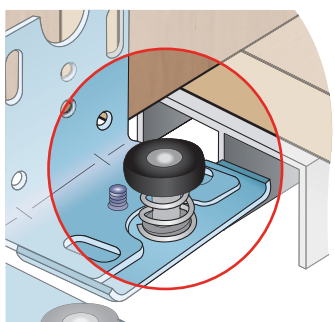

Kování je shodné s kováním H20/H30

Montáž dvojité  
hliníkové lišty

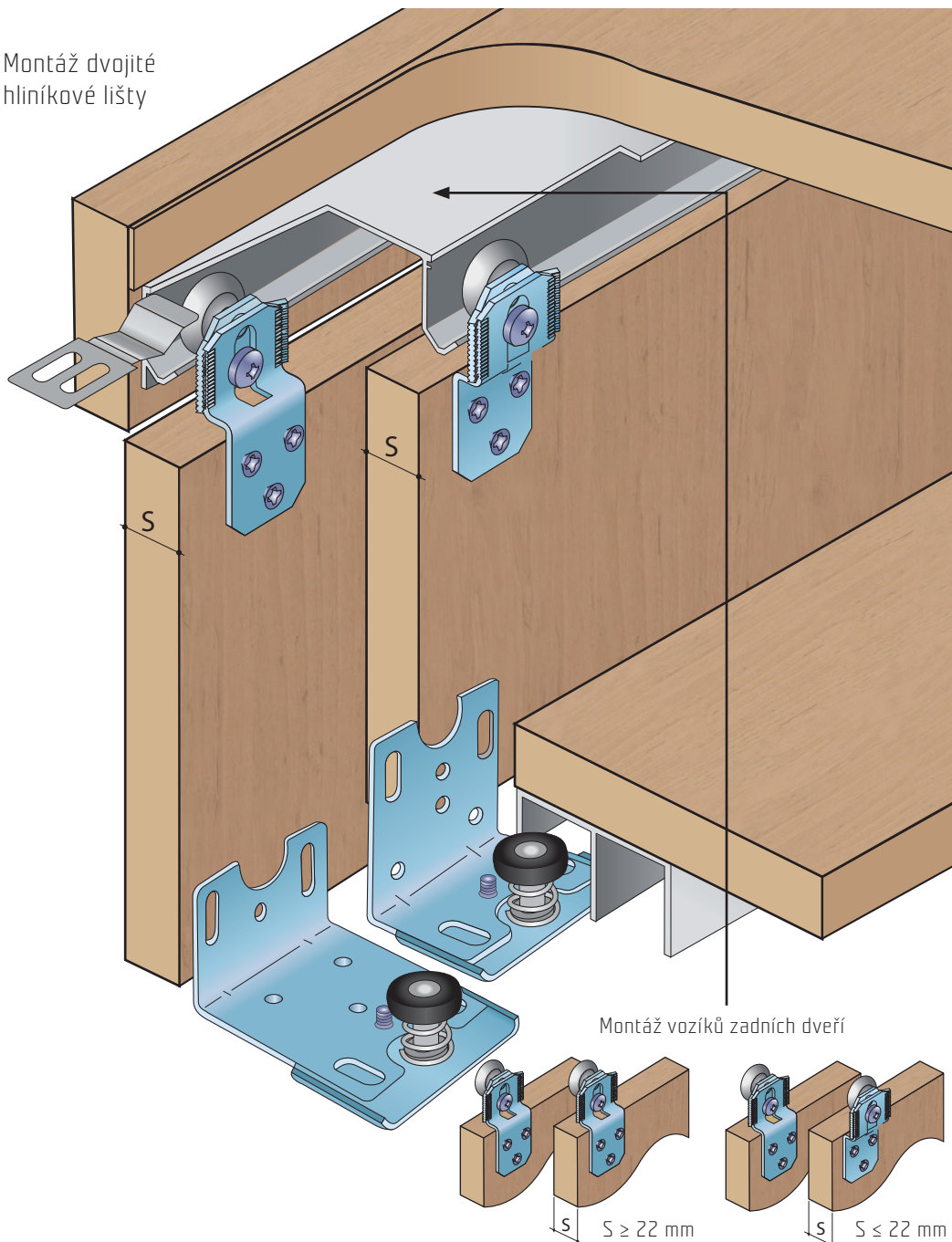

## SOUČÁSTI SYSTÉMU:

Sada S30

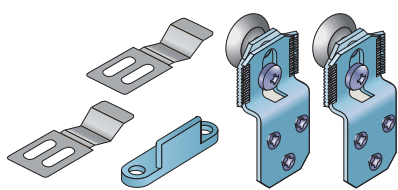

Sada S20

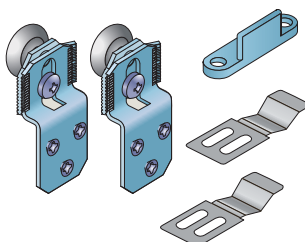

Dolní vedení S30 – sada

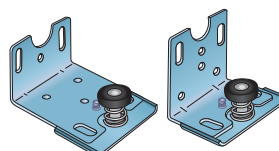

Dolní vodící profil S30

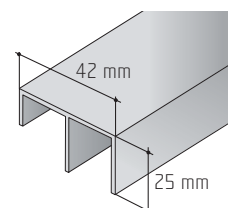



30 kg



kuličkové  
ložisko (S30)



min.  
18 mm



horní  
vedení

## Montáž sady S20

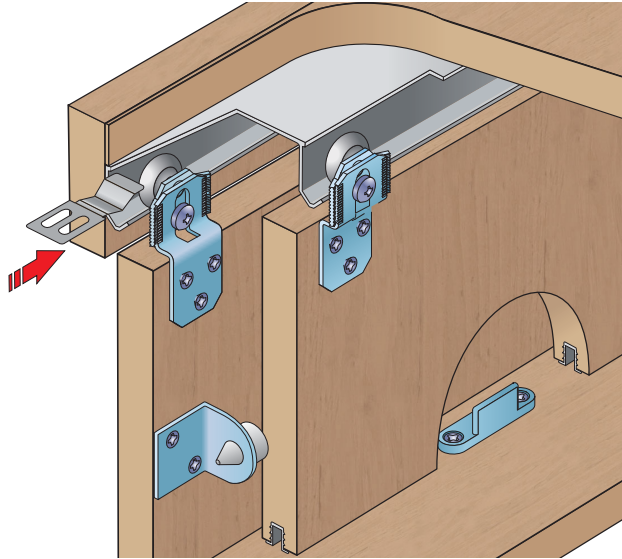

## S20/S30

Kování S20/S30 je určeno pro výrobu skříní s posuvnými dveřmi. Je dodáváno se dvěmi variantami vodících lišt, kdy dvojitá vodící lišta umožňuje montáž bez nutnosti překrytí vodícího profilu deskou.

1

2

3

3b

Varianta s dolním vedením

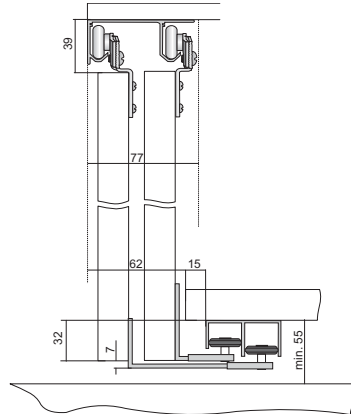
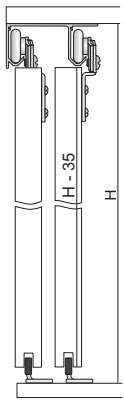
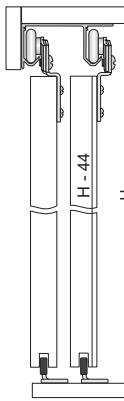
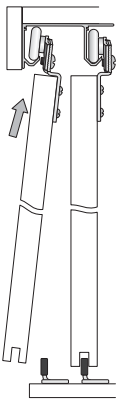
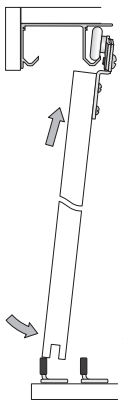

3 Montáž vozíků a brzd

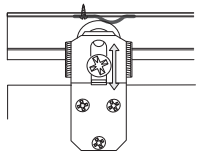

3b Varianta montáže bez krycí desky

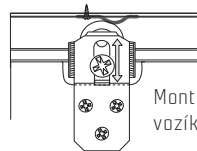

Montáž vozíků a brzd

4 Drážka pro spodní lištu

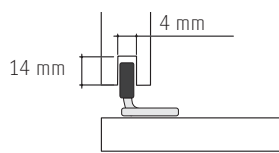

Profil S20/S30 jednoduchý

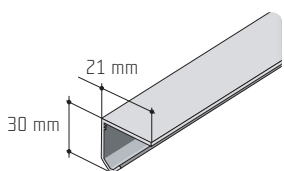

Profil S20/S30 dvojitý

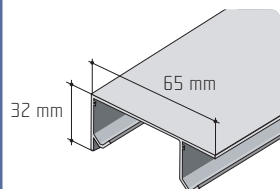

Ocelová lišta S20/S30

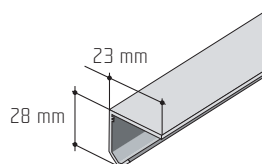

# S25

PRO SKLÁDACÍ  
DVEŘE

Detail horního vozíku  
(pro levé i pravé dveře)

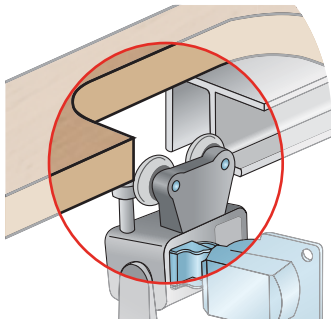

Detail dolního vozíku  
(pro levé i pravé dveře, možnost  
montáže i pod dno skříně)

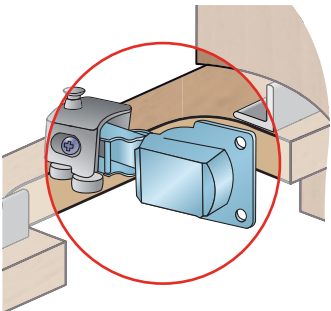

Středové závěsy součástí sady

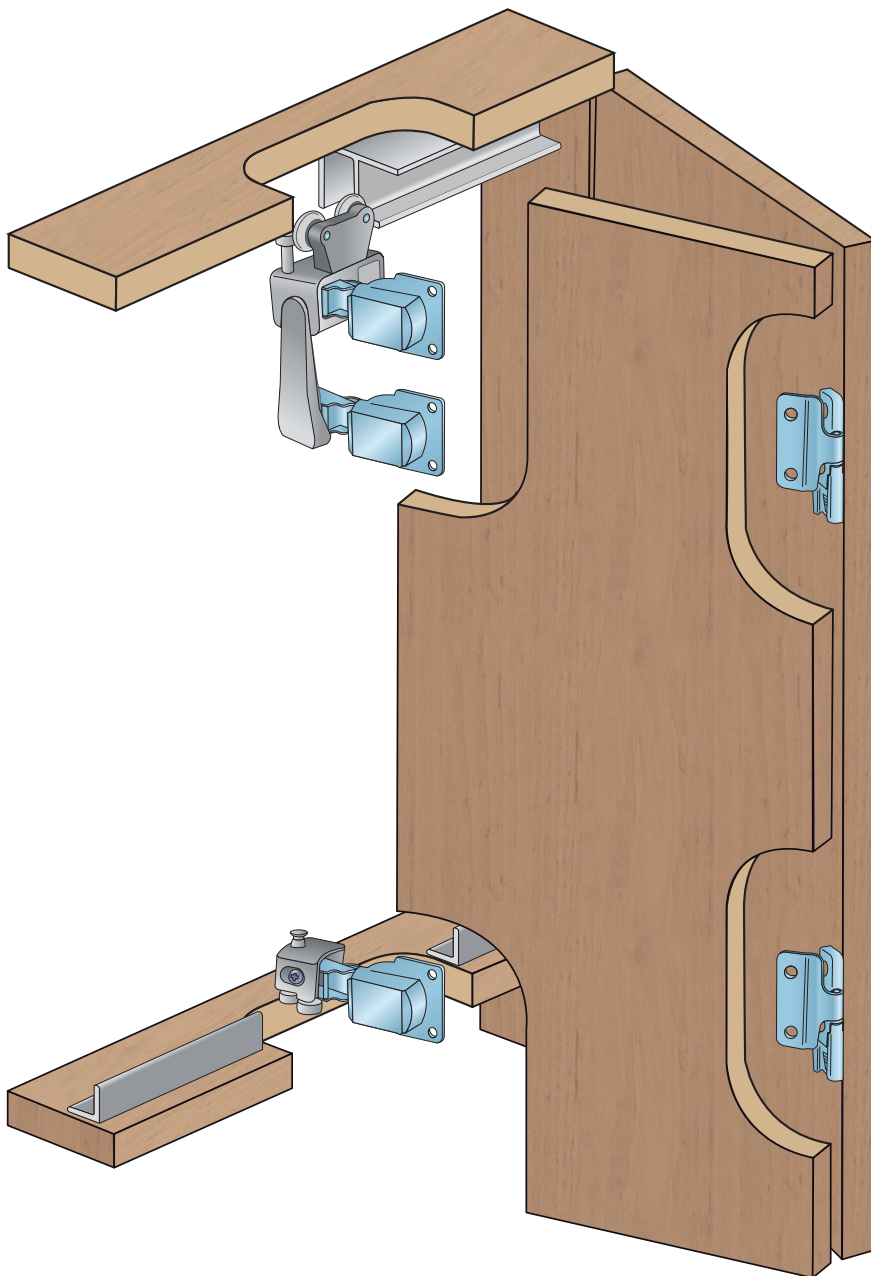
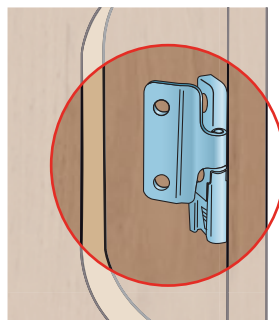

## SOUČÁSTI SYSTÉMU:

Sada S25

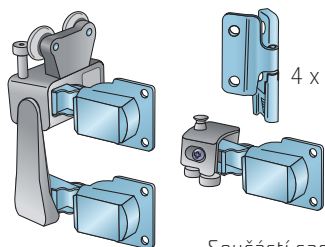

Součástí sady  
4 x naložený závěs

Horní lišta

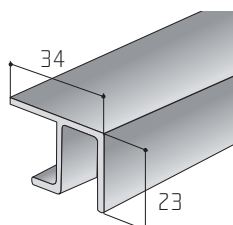

Spodní lišta

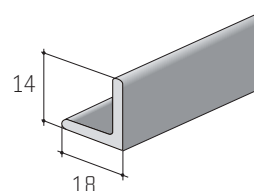



25 kg



kuličkové  
ložisko



min.  
16 mm



Horní  
vedení

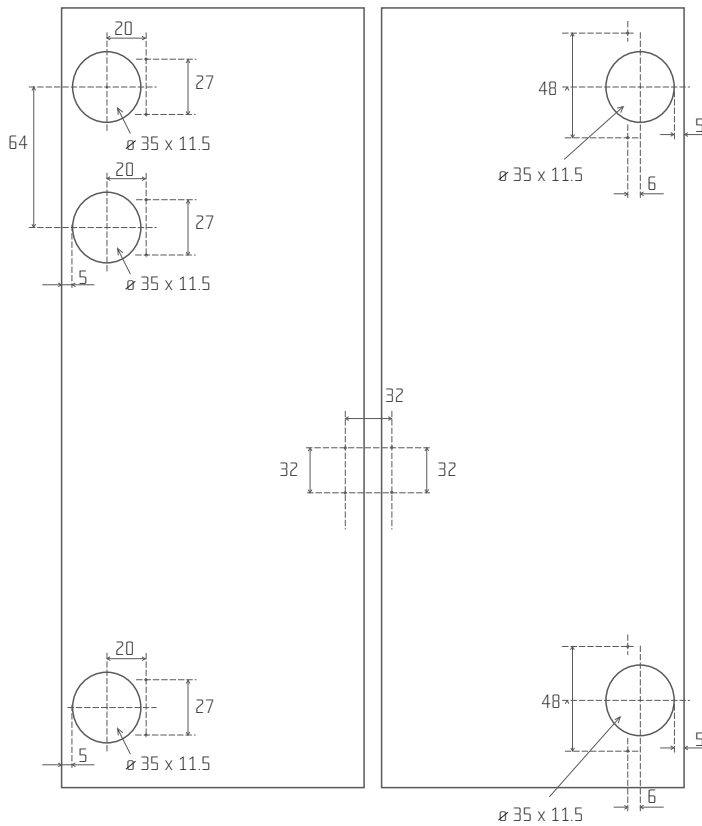
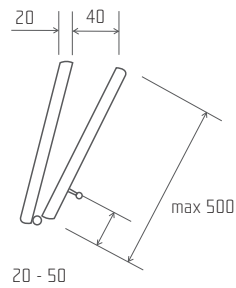

## S25

System pro skládací dveře do skříní. Dolní vozík umožňuje montáž na dno i pod dnem skříně. Vozíky jsou vyrobeny z odolného plastu, horní vozík má namáhané díly z ocelového plechu, který je krytý plastovým dílem, takže je nejenom zaručena výborná funkčnost, ale i estetický dojem.

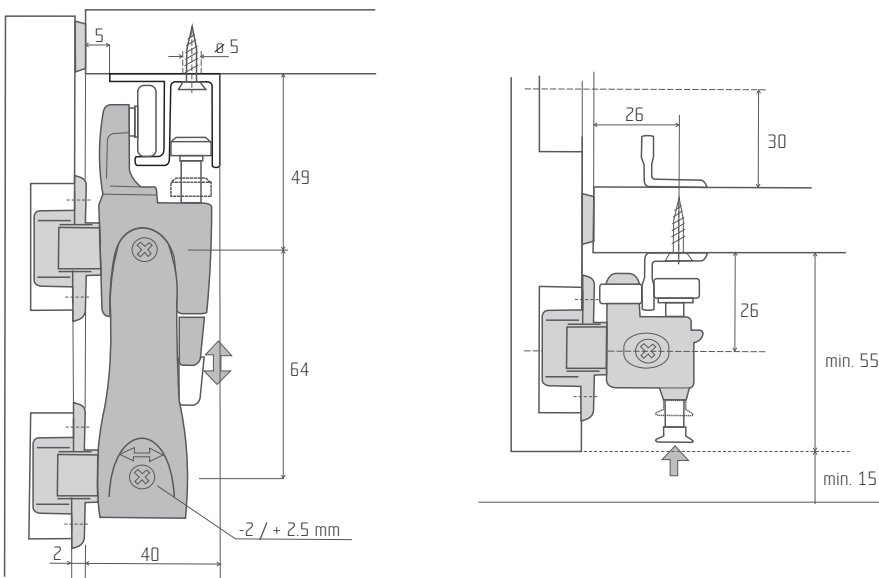

# S27AL/S37AL

PRO POSUVNÉ  
HLINÍKOVÉ RÁMY

Brzda horního vozíku

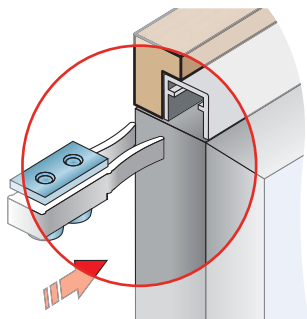

Výškové seřízení dvířka

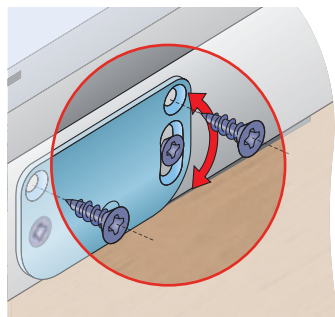

Výškové seřízení dolního vozíku

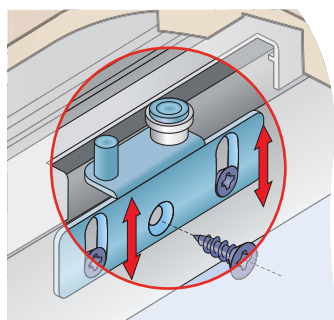

Kování je shodné s kováním H27AL/H37AL

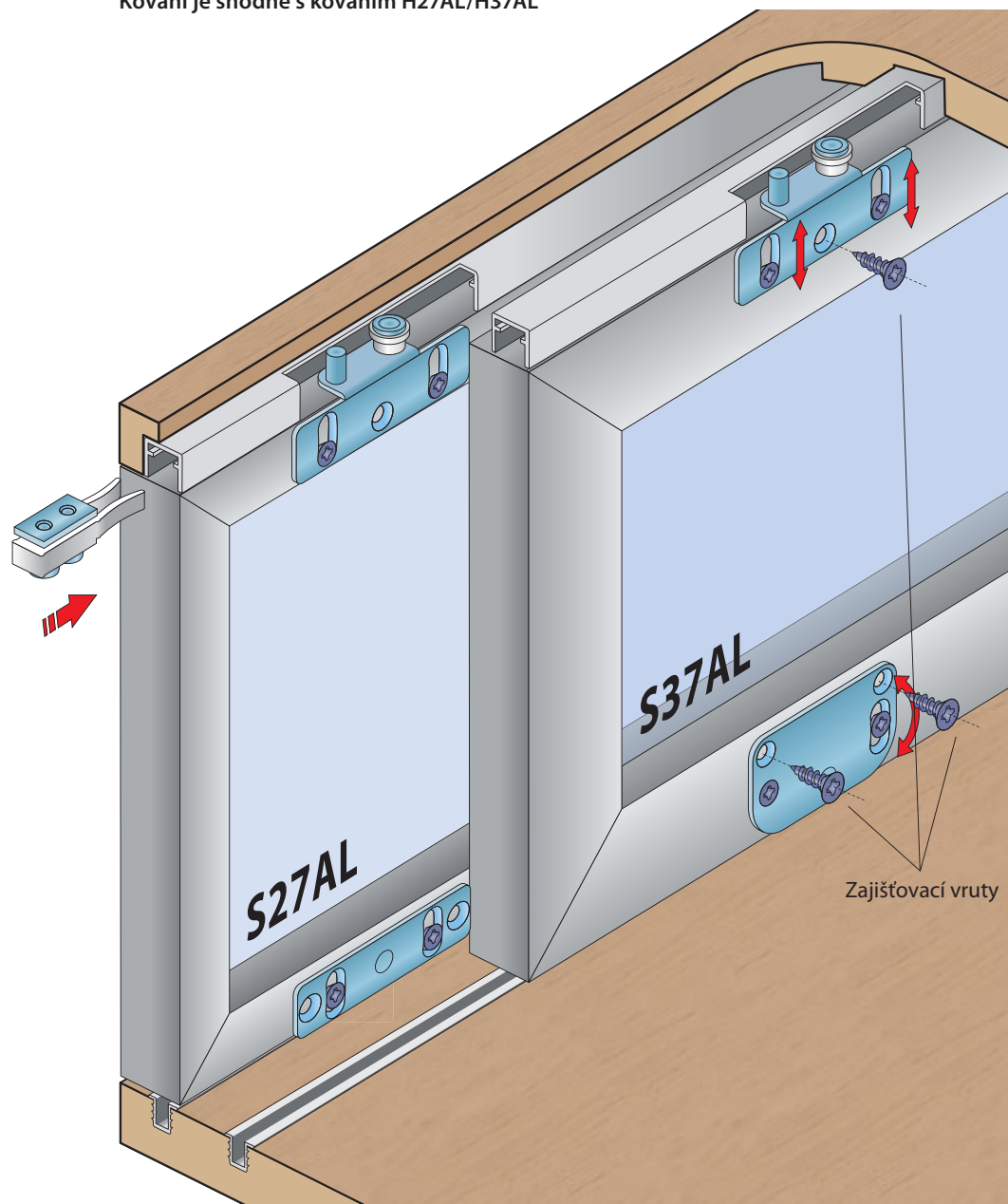

## SOUČÁSTI SYSTÉMU:

Sada S27AL/S37AL

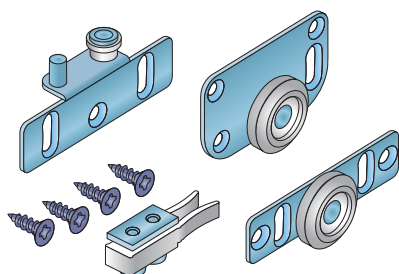

Horní profil S50

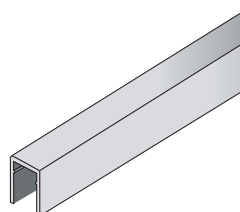

Profil S03

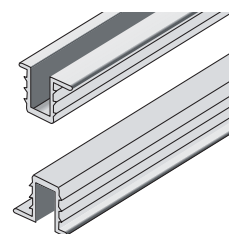





25/35 kg



kuličkové ložisko



spodní vedení

## S27AL

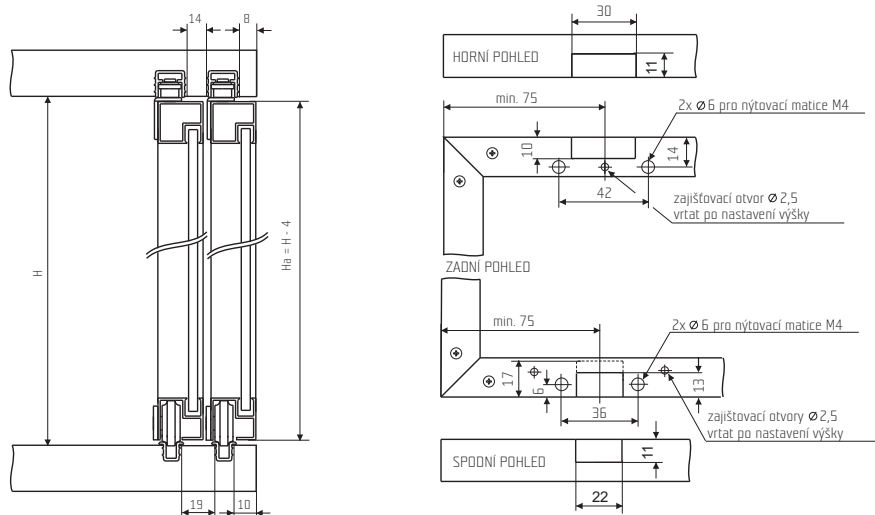

Určeno pro profily A, B, H a I.

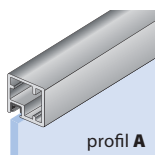

profil A

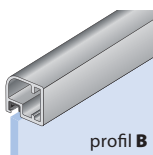

profil B

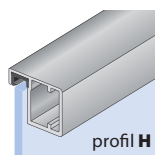

profil H

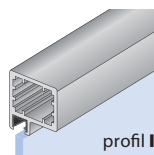

profil I

## S37AL

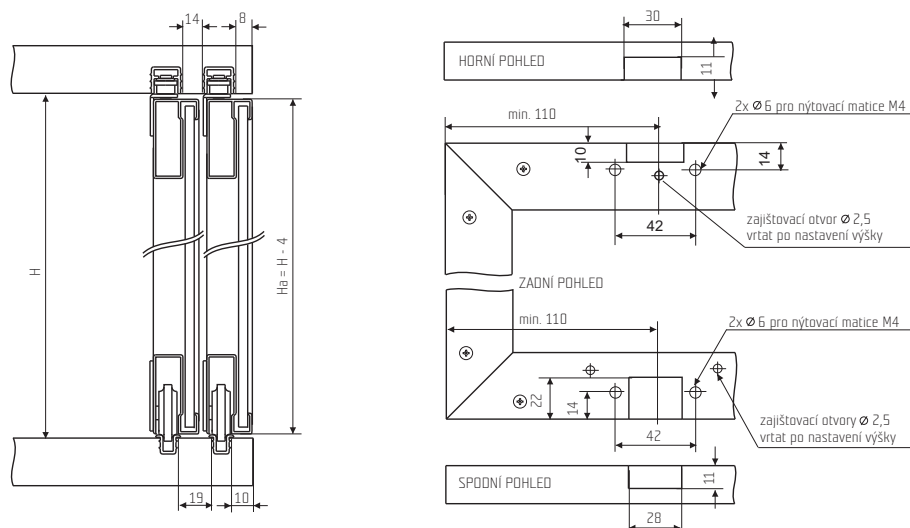

Určeno pro profily C, D, D1, E, F, F1, G, J a K.

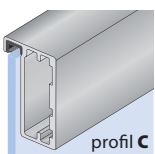

profil C

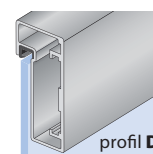

profil D

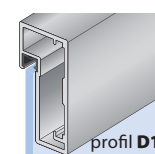

profil D1

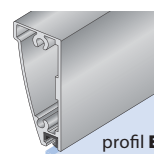

profil E

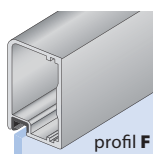

profil F

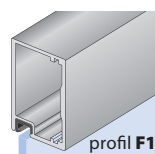

profil F1

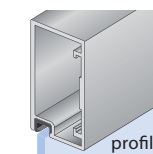

profil G

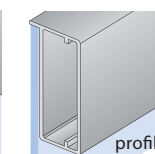

profil J

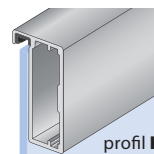

profil K

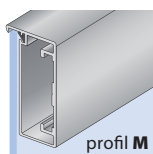

profil M



## S27AL/S37AL

Nábytkové kování S27AL a S37AL představuje designově čisté řešení posuvných hliníkových rámků. Systém lze použít pro posuvné hliníkové rámy v kuchyňských linkách, pro menší skříně a pro různé samostatné kusy nábytku. Nosnost jednoho křídla je 25 kg (S27AL) resp. 35 kg (S37AL). Pro systém jsou použity hliníkové vodící profily, které se narážejí do vyfrézovaných drážek do dna a stropu skříně. Kování S27AL a S37AL lze kombinovat se systémem S37, které je určeno pro laminové dveře.

# S34

PRO POSUVNÉ  
HLINÍKOVÉ RÁMY

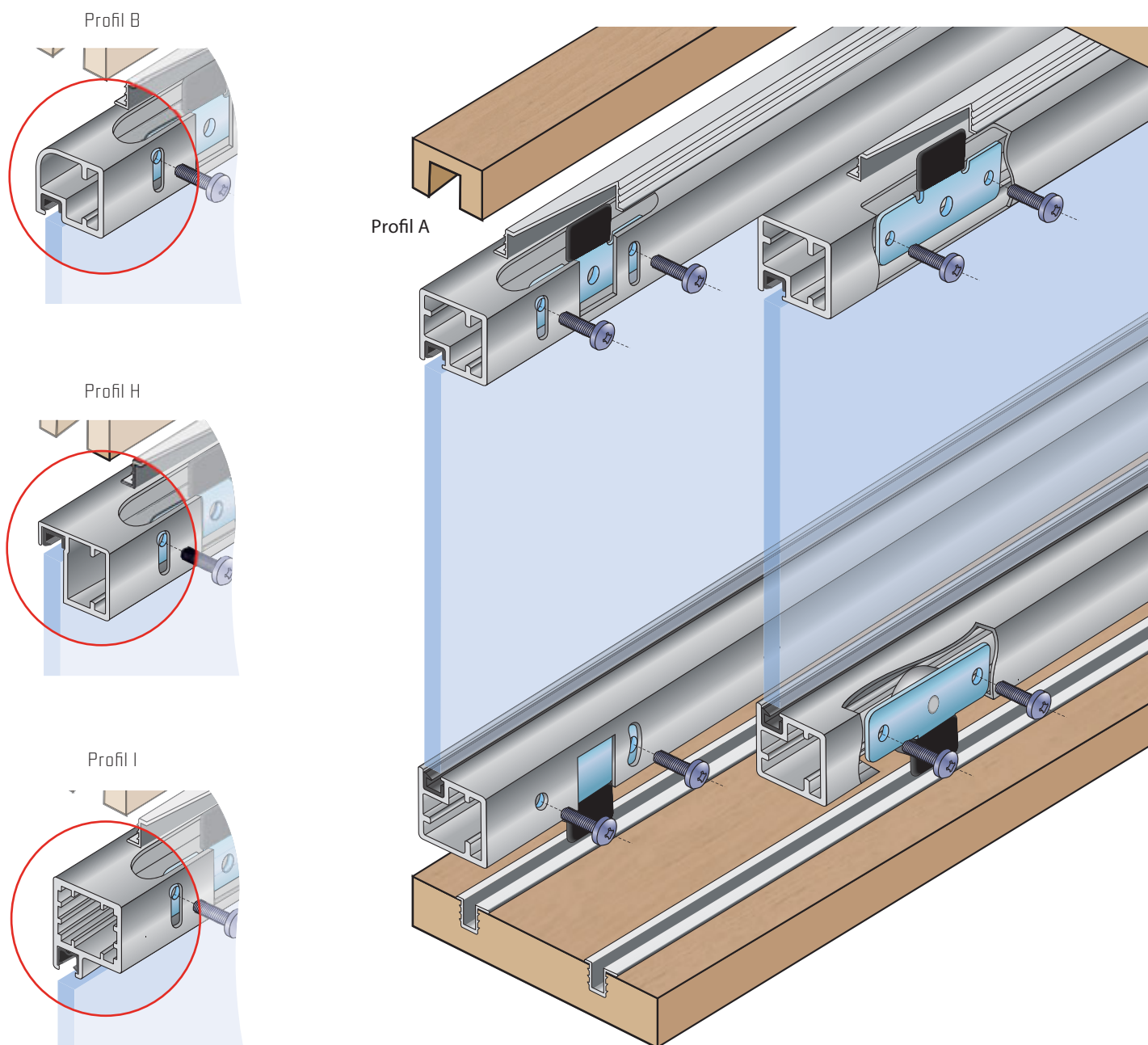

## SOUČÁSTI SYSTÉMU:

Sada S34 Alu

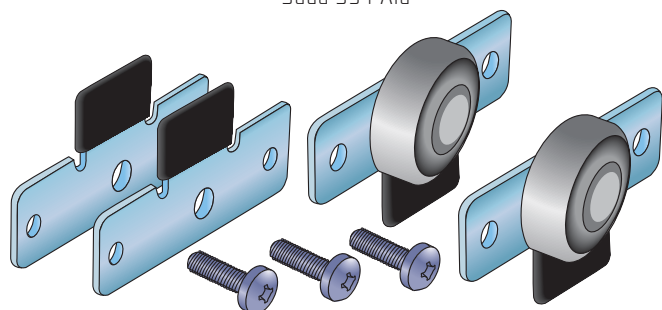

Profil S03

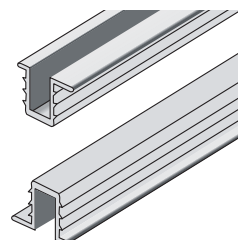



34 kg



kuličkové  
ložisko



sklo  
4 mm



spodní  
vedení

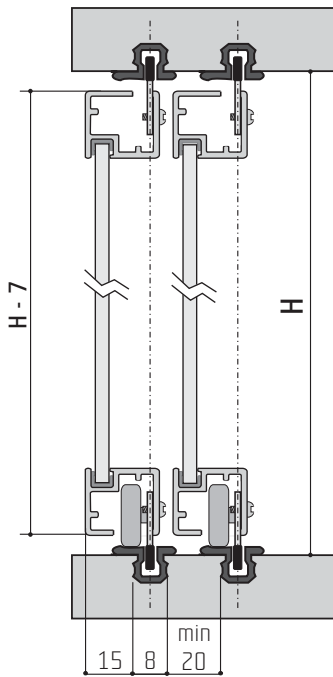

Profil A



Profil B



Profil H



Profil I

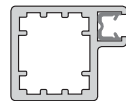

Horní vodítko

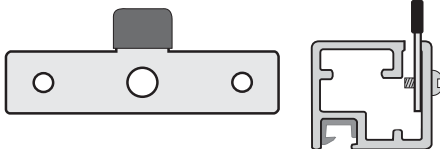

Jezdec s ložiskovým kolečkem  
a výškovou regulací

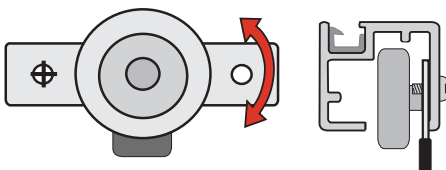

Šířka a hloubka frézování  
pro vodící profil:

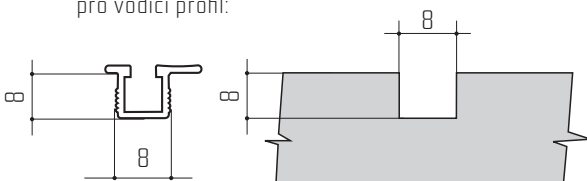

Vodící profil S03  
(elox, délky 1,25; 2; 2,5; 3; 6 m)

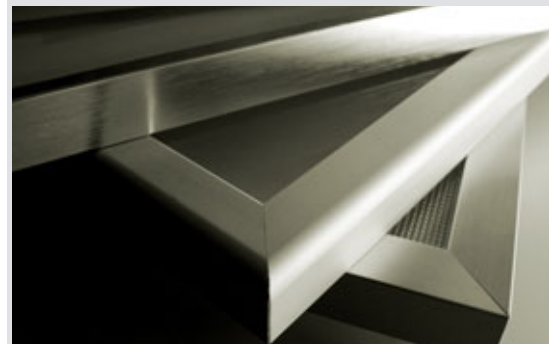
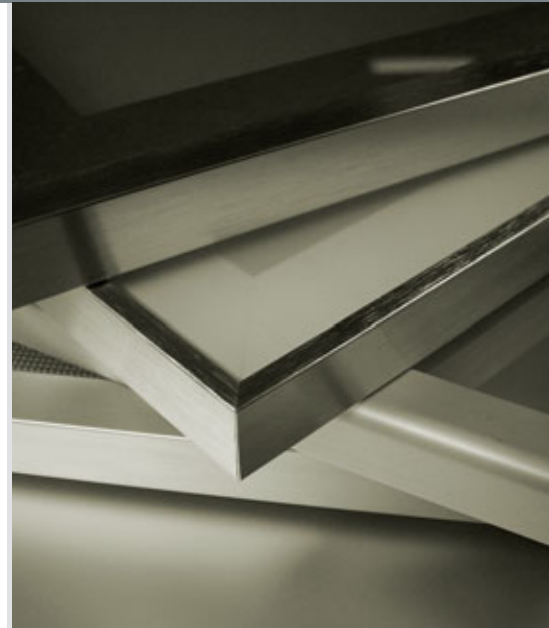

## S34

Kování pro posuvné dveře S34 ALU je určeno pro úzké hliníkové rámečky. Používá shodný typ vodící lišty jako kování S35, což umožňuje kombinovat v jedné skříni dřevěná a hliníková dvířka. Spodní vozík umožňuje jemné výškové nastavení dvířek, tak aby byly korigovány případné nerovnosti korpusu.

# S35

PRO POSUVNÉ  
SKŘÍŇOVÉ DVEŘE

Kluzák S35A

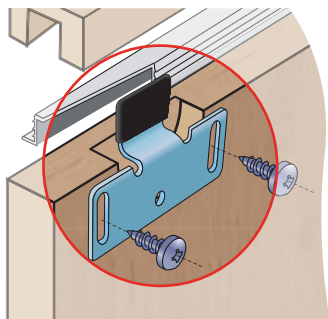

Kluzák S35B

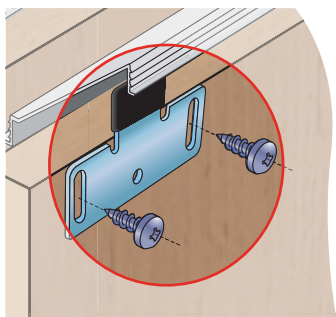

Dorazový profil

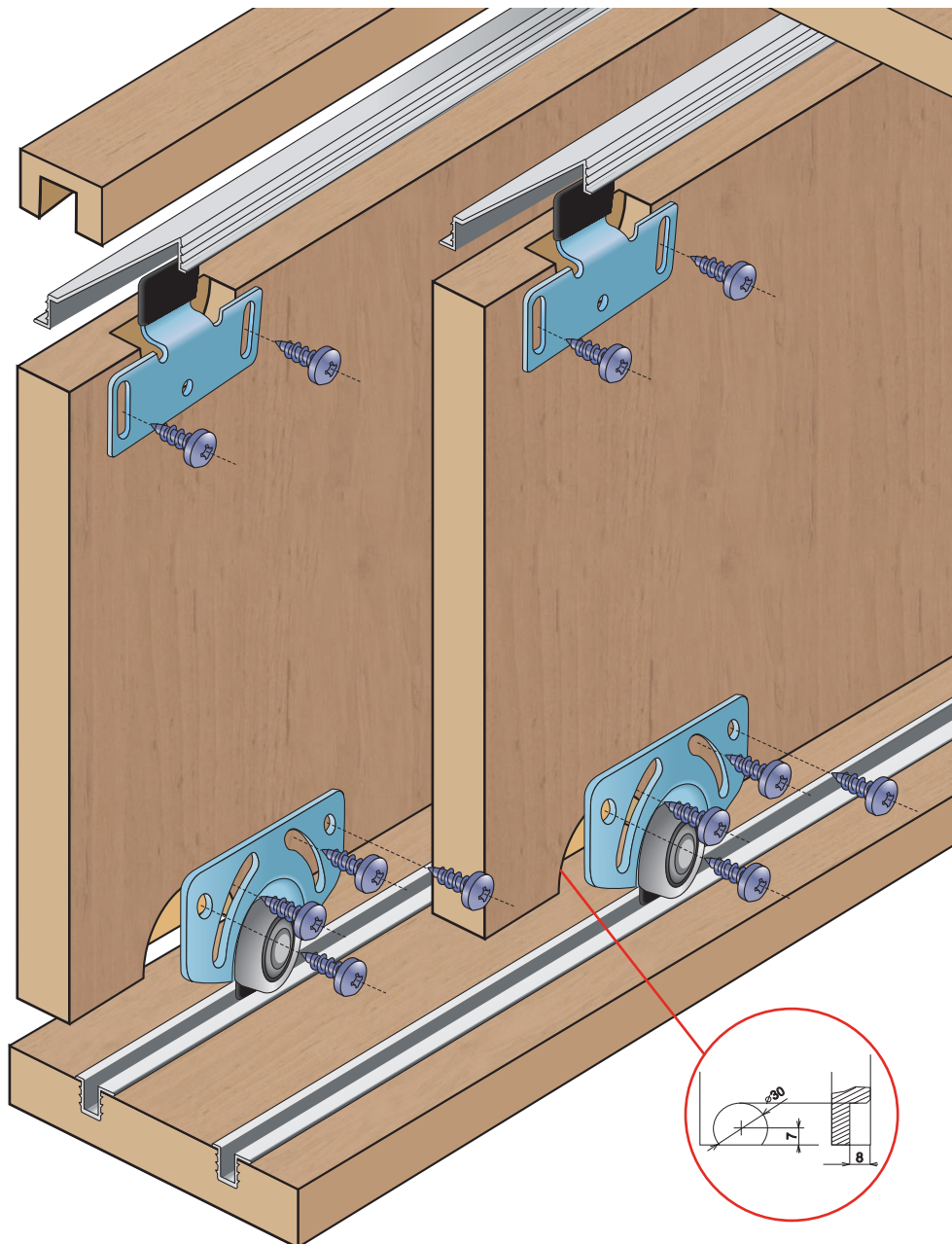
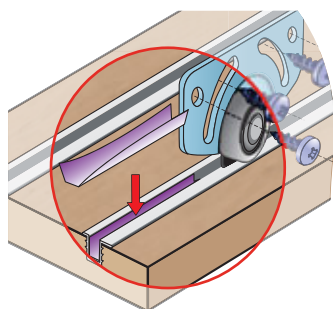

## SOUČÁSTI SYSTÉMU:

Profil S03

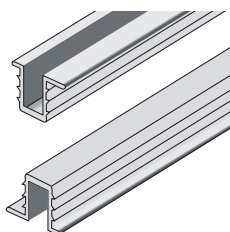

Kluzák S35A

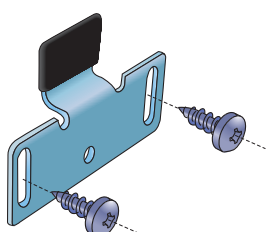

Kluzák S35B

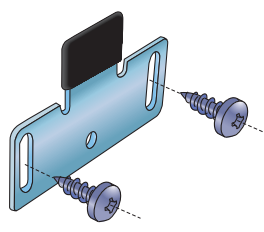

Vozík S35C

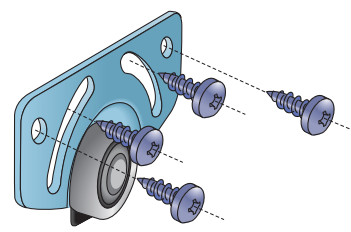



35 kg



kuličkové ložisko



min. 18 mm



spodní vedení

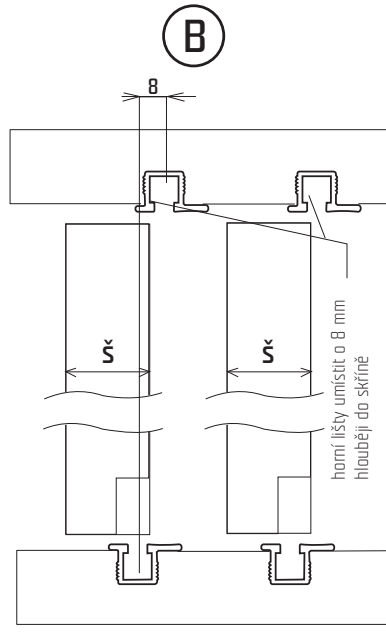
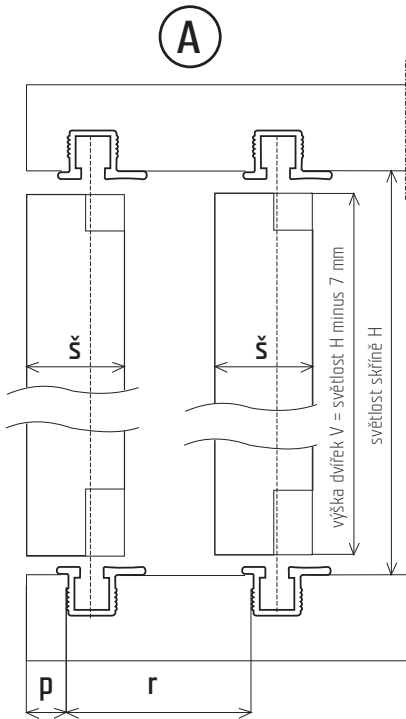

Vzdálenost frézování pro první lištu od okraje minimálně:

$$p = \text{š} - 8 \text{ mm}$$

Rozteč frézování pro druhou lištu:

$$r = \text{š} + \text{min. } 7 \text{ mm}$$

Příklad pro lamino tl. 18 mm

$$p = 10 \text{ mm}$$

$$r = 25 \text{ mm}$$

$$V = H - 7$$

Zafrézování pro horní vozík:

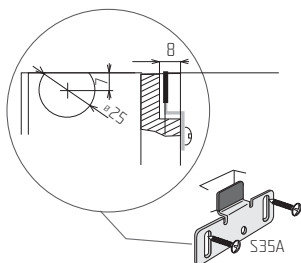

Šířka a hloubka frézování pro vodící profil:

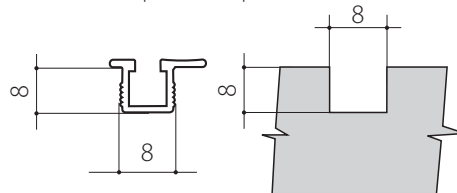

Montáž a seřízení:

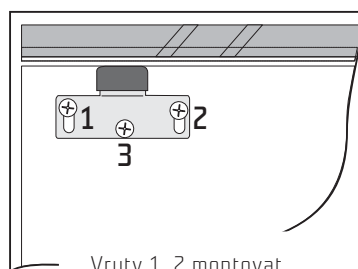

Vruty 1, 2 montovat před nasazením dveří, vruty 3, 4 po nasazení a seřízení dveří.

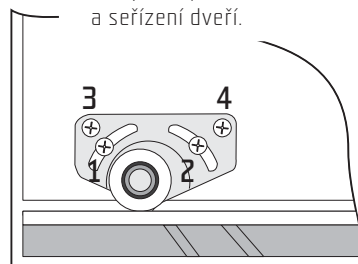

Dorazový profil S35

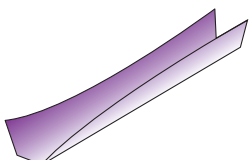

## S35

Kování pro posuvné dveře S35 v sobě spojuje přednosti ve velké míře používaných plastových typů (jednoduchá montáž, nastavení a nízká cena), ale je tvrdou konkurencí i pro systémy kování pro posuvné dveře s hliníkovými nebo ocelovými lištami a ocelovými vozíky. Kování S35 se cenou blíží plastovým typům, montáž je stejná jako u plastových typů, robustnost je však na úrovni mnohem dražších systémů.

# S36

PRO POSUVNÉ  
SKŘÍŇOVÉ DVEŘE

Montáž brzdy

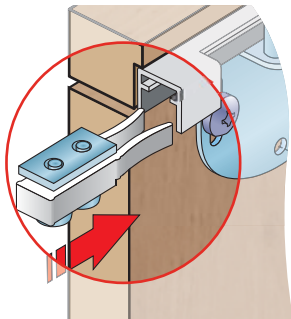

Možnost seřízení  
horního vozíku

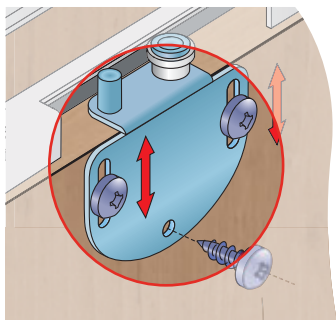

Možnost seřízení  
dolního vozíku

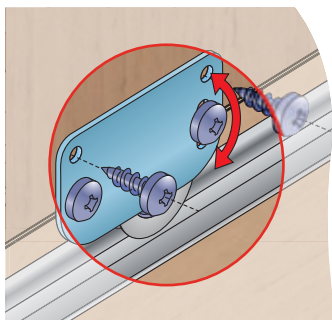

Kování je shodné s kováním H35

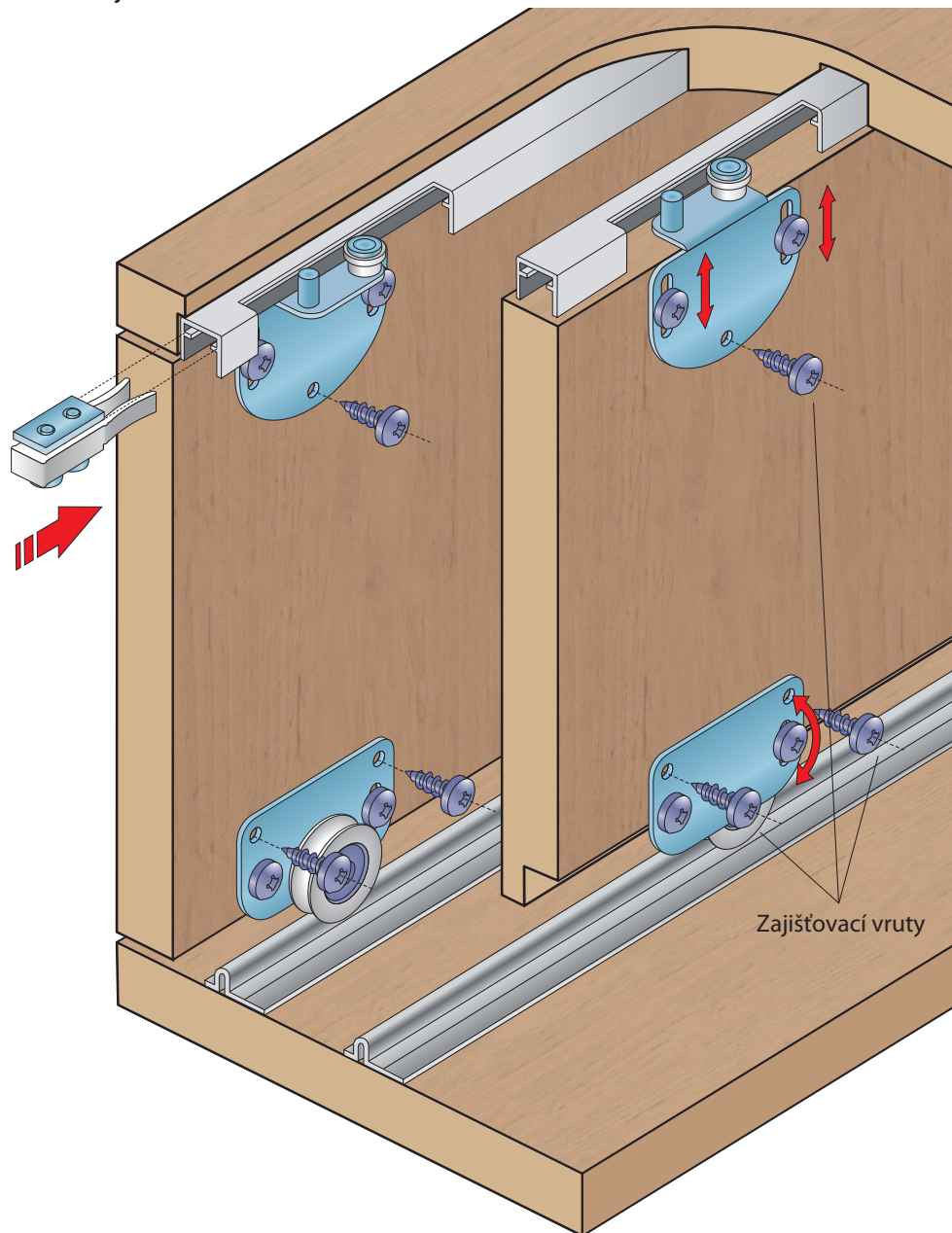

## SOUČÁSTI SYSTÉMU:

Sada S36

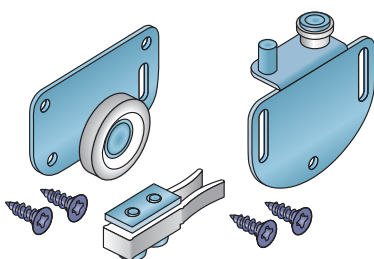

Spodní profil S50

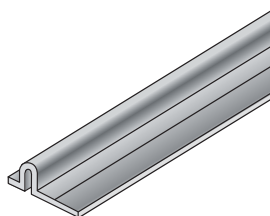

Horní profil S50

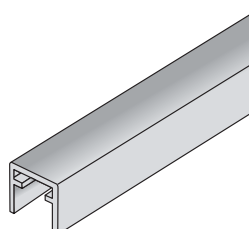

Brzda

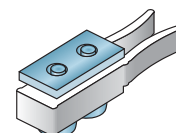



35 kg



kuličkové  
ložisko



min.  
18 mm



spodní  
vedení

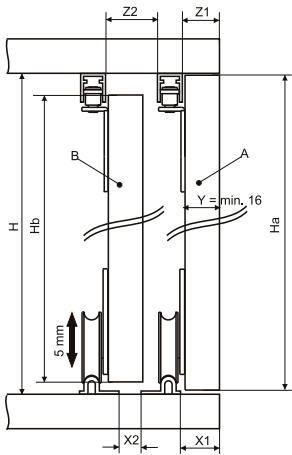

$H_a = H - \text{min. } 4$   
 $H_b = H - 20$   
 $X_1 = Y + 3$   
 $X_2 = Y - 13,5$   
 $Z_1 = Y + 4$   
 $Z_2 = Y + 5$

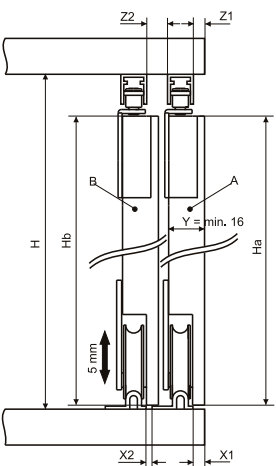
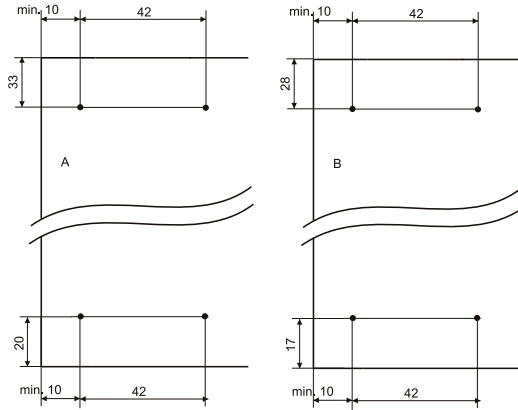

$H_a = H_b = H - \text{min. } 20$   
 $X_1 = Y - 12$   
 $X_2 = Y - 12,5$   
 $Z_1 = Y - 13,5$   
 $Z_2 = Y - 5$

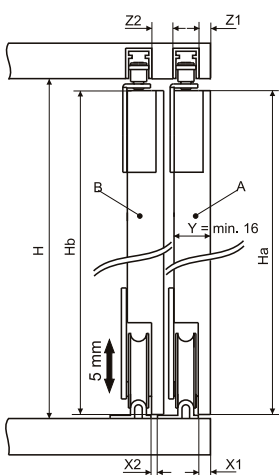
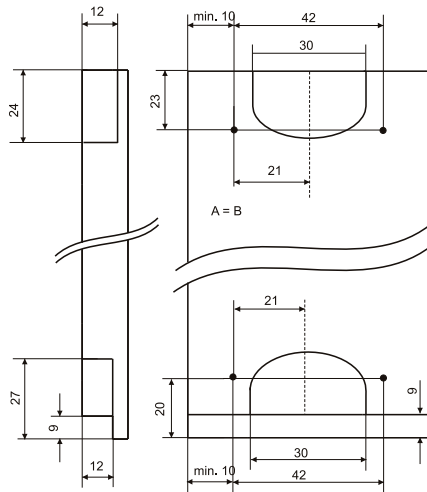

$H_a = H_b = H - \text{min. } 4$   
 $X_1 = Y - 12$   
 $X_2 = Y - 12,5$   
 $Z_1 = Y - 13,5$   
 $Z_2 = Y - 5$

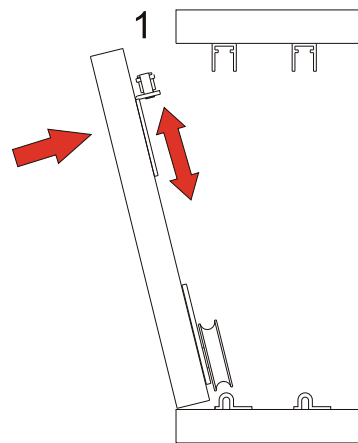

1. V prvním kroku se zašroubují vozíky na dveře. Dále je třeba spustit horní vozík, aby bylo možno zasunout dveře s vozíky do dolních lišt.

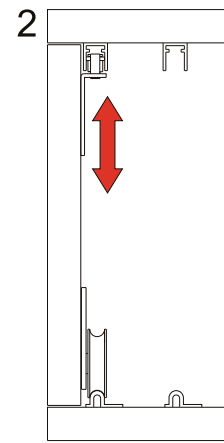

2. Po umístění dveří s vozíky do dolních lišt se zvedne horní vozík do horní lišty a po výškovém nastavení se zafixuje v požadované poloze pomocí zajišťovacích šroubů.



## S36

Kování S36 je navrženo s ohledem na maximální využití vnitřního prostoru skříně. Kování je určeno pro laminovou nebo dřevěnou výplň. Pro systém jsou použity hliníkové vodící profily, které se montují do dna a stropu skříně. Nosnost jednoho křídla je 35 kg.

# S37

PRO POSUVNÉ  
SKŘÍŇOVÉ DVEŘE

Brzda horního vozíku

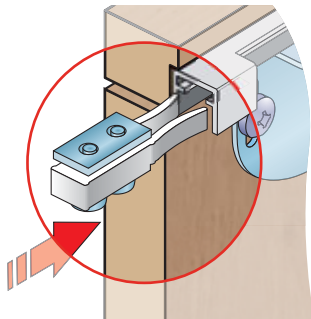

Montáž dolního vozíku  
z vnější strany desky

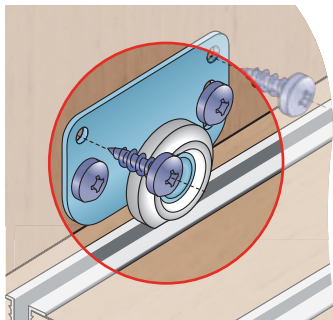

Montáž vozíku  
se zafrézováním kolečka

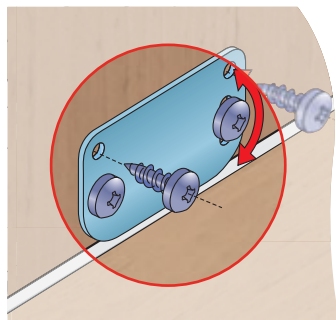

Kování je shodné s kováním H37

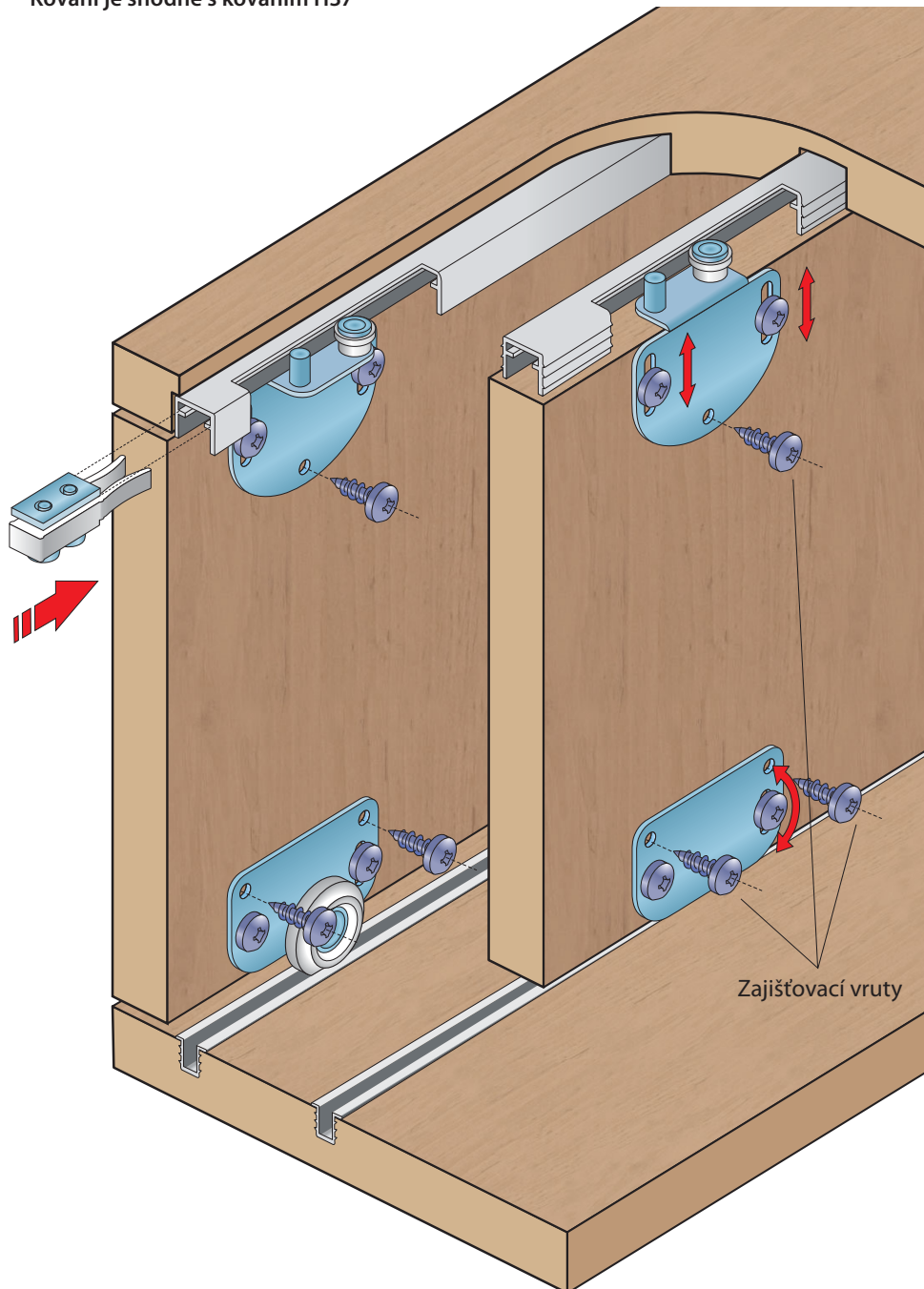

## SOUČÁSTI SYSTÉMU:

Sada S37

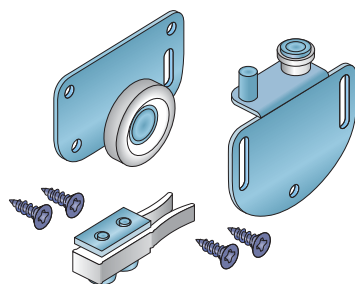

Horní profil S50

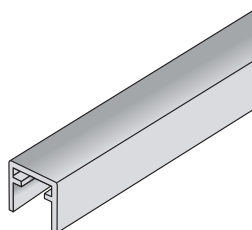

Profil S03

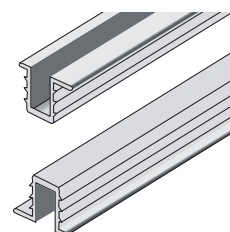





35 kg



kuličkové  
ložisko



min.  
16 mm



spodní  
vedení

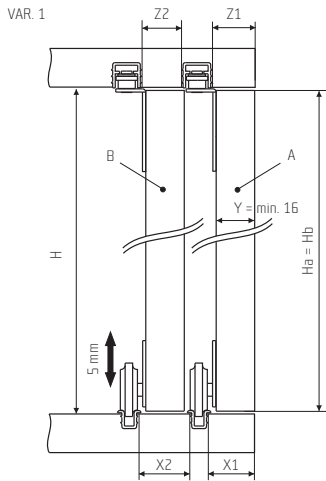

$$\begin{aligned}
 H_a &= H_b = H - \text{min. } 4 \\
 X_1 &= Y + 5 \\
 X_2 &= Y + 8,5 \\
 Z_1 &= Y + 3 \\
 Z_2 &= Y + 2,5
 \end{aligned}$$

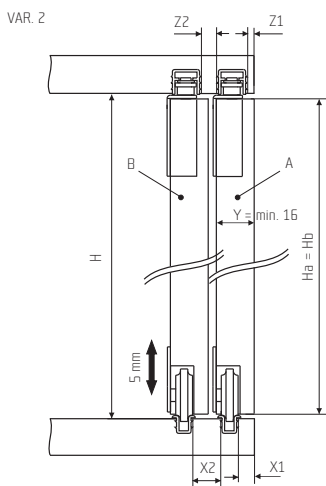
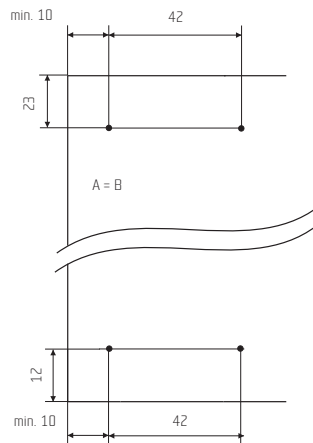

$$\begin{aligned}
 H_a &= H_b = H - \text{min. } 4 \\
 X_1 &= Y - 6 \\
 X_2 &= Y - 1 \\
 Z_1 &= Y - 10 \\
 Z_2 &= Y - 7
 \end{aligned}$$

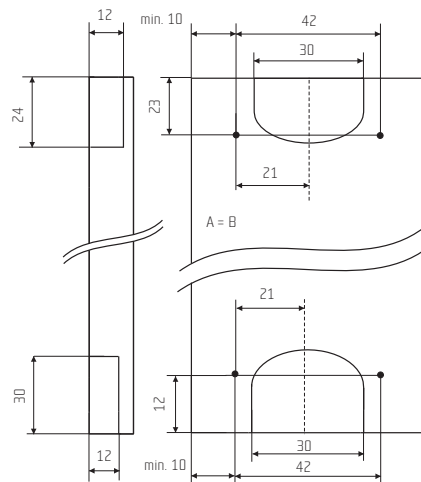

### Montáž dveří

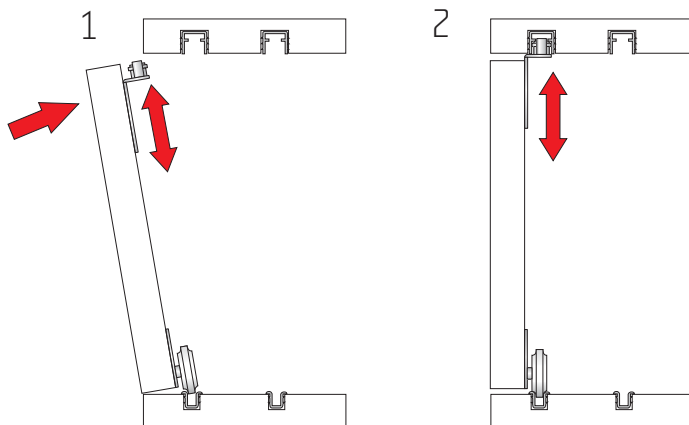

1. Vozíky se uchytní na dveře dle výše uvedeného vrtacího plánu. Horní vozíky jsou přítom v dolní poloze.
2. Dveře se zasunou dolními vozíky do dolní lišty, horní vozíky se zasunou do horní lišty a dotáhnou vruty.
3. Po výškovém seřízení dveří se poloha dveří zafixuje zajišťovacími vruty.



## S37

Kování S37 je navrženo s ohledem na maximální využití vnitřního prostoru skříně. Kování je určeno pro laminovou nebo dřevěnou výplň. Pro systém jsou použity hliníkové vodící profily, které se narážejí do vyfrézovaných drážek do dna a stropu skříně. Nosnost jednoho křídla je 35 kg.

# S40/S40H

PRO POSUVNÉ  
SKŘÍŇOVÉ DVEŘE

Montáž horního vozíku

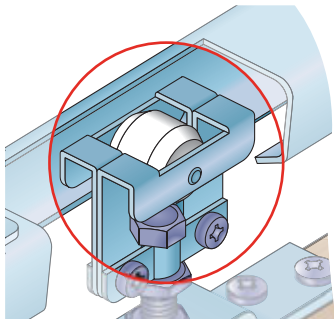

Montáž brzdy

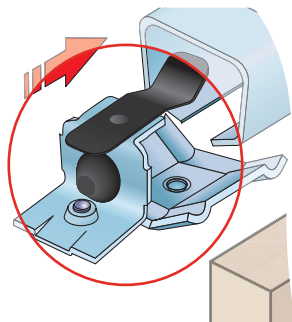

Montáž spodního vodítka

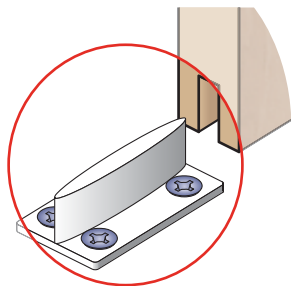

Kování je shodné s kovááním H40/H40 Hard

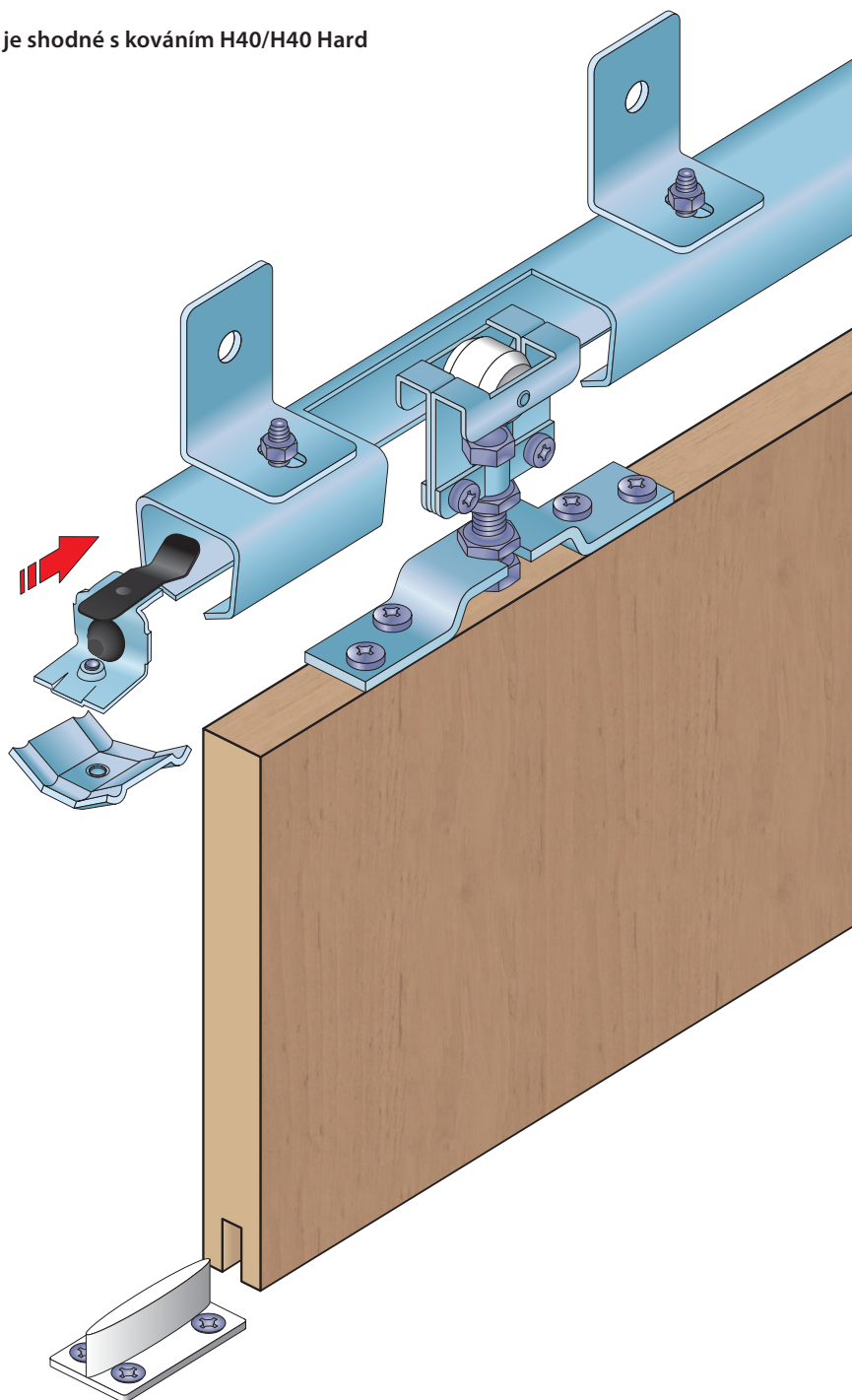

## SOUČÁSTI SYSTÉMU:

Sada S40

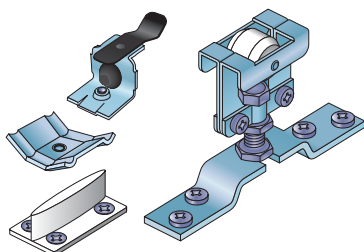

Sada S40H

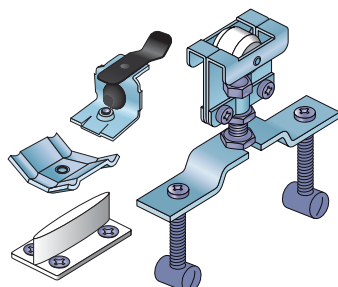

Horní ocelový profil S40/S80

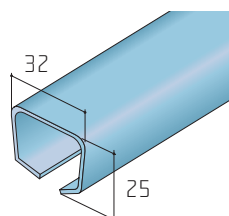

Horní hliníkový profil S40/S80

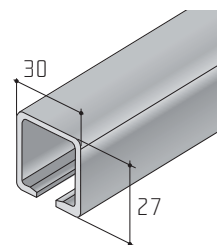



40 kg



kuličkové ložisko



min. 18 mm



horní vedení

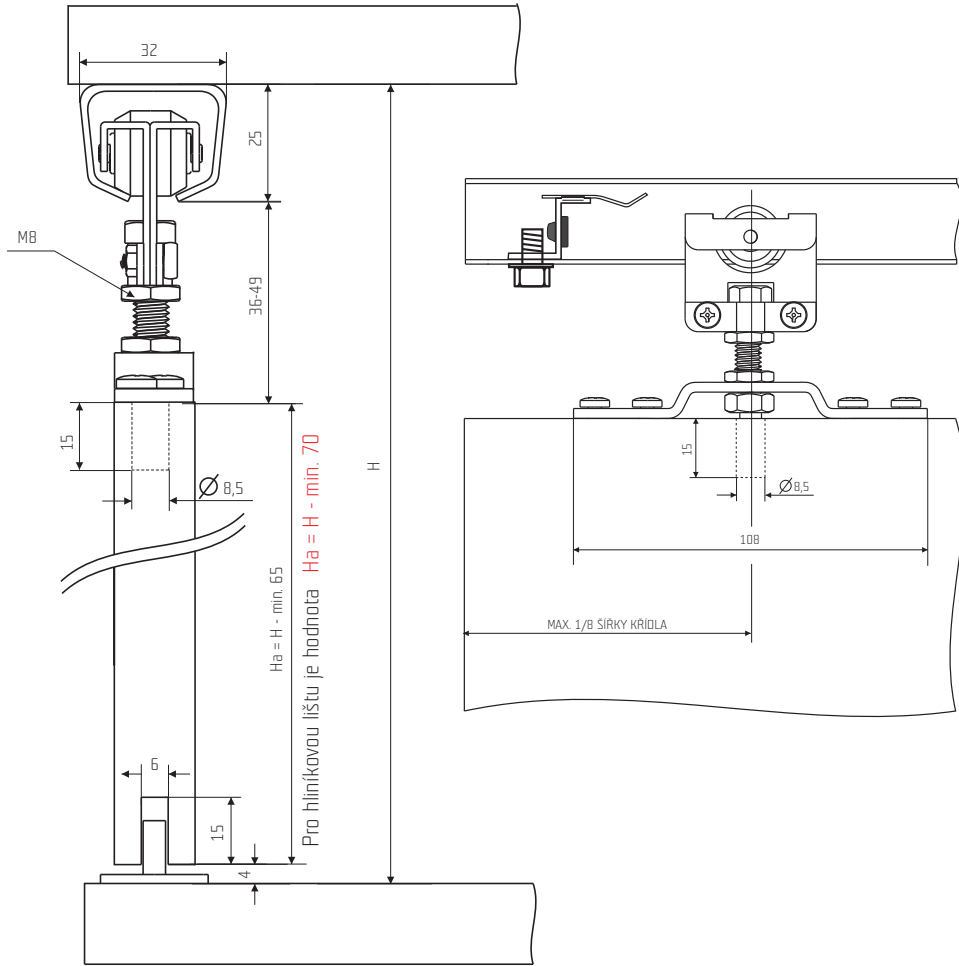

### SOUČÁSTI SYSTÉMU:

Úchyt lišty boční

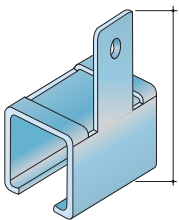

Úchyt lišty horní

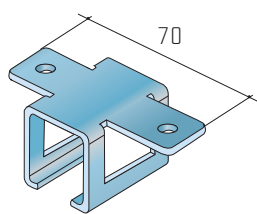

Brzda S40/S80

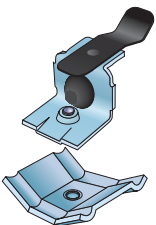

Plastové vodítko

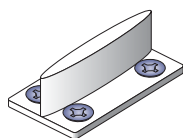

Stěnová příchytkka

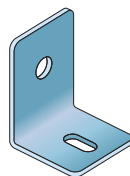

## S40

Nábytkové kování S40 představuje jednoduché řešení pro posuvné průchozí dveře a posuvné stěny. Systém se vyznačuje tichým chodem jednoduchou montáží. K systému je k dispozici jak hliníková tak ocelová vodící lišta. Varianta kování S40H je určena pro montáž do lamina pomocí spojovacích nábytkových válečků, které jsou součástí sady kování.

# S40SD

PRO SKLÁDACÍ  
DVEŘE

Detail horního vozíku  
(vyrábí se levé a pravé provedení)

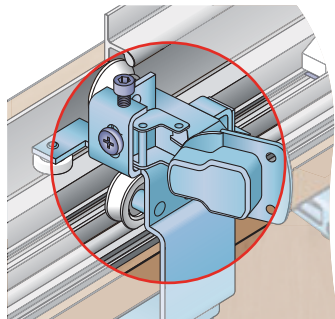

Detail dolního vozíku

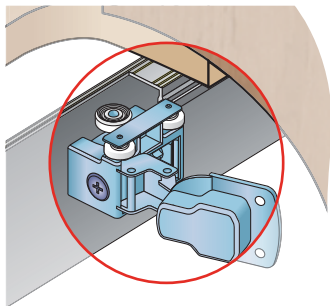

Detail středového závěsu

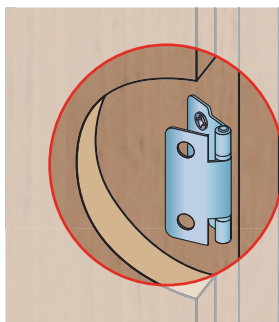

Kování je shodné s kováním H40SD

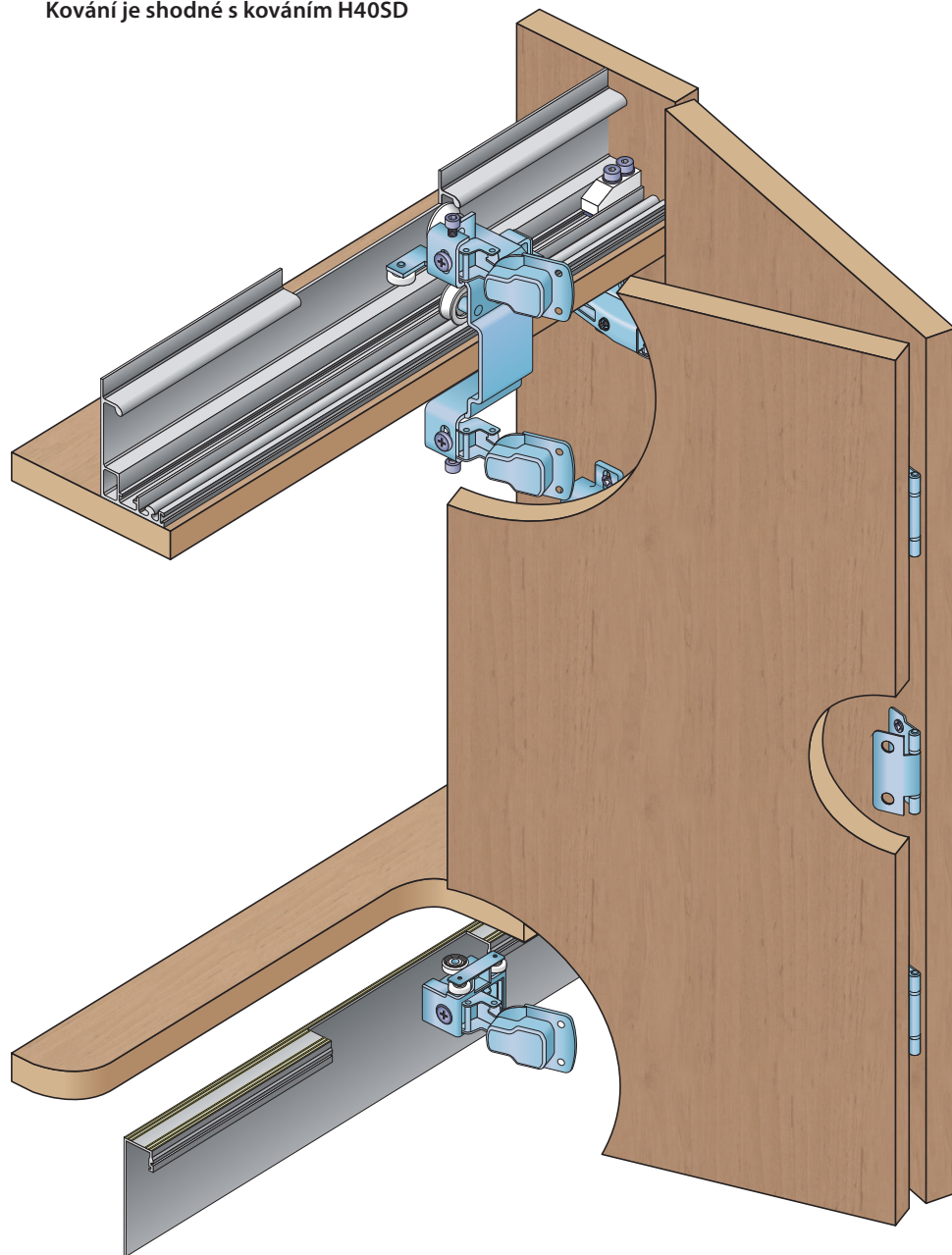

## SOUČÁSTI SYSTÉMU:

Sada S40SD

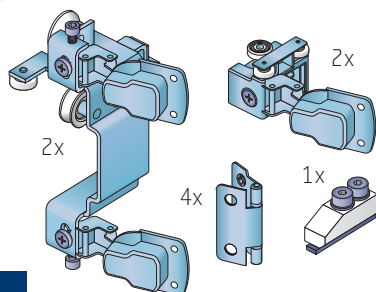

Horní lišta S40SD

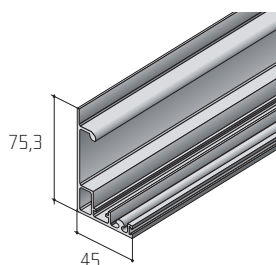

Dolní lišta S40SD

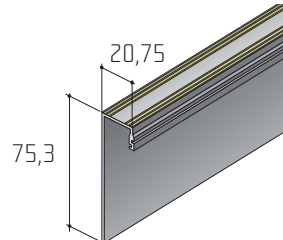

Protiprachový kartáček





40 kg



kuličkové  
ložisko



min.  
16 mm



horní  
vedení

Sestava dveří se 2 křídly

VRTACÍ PLÁN H40SD

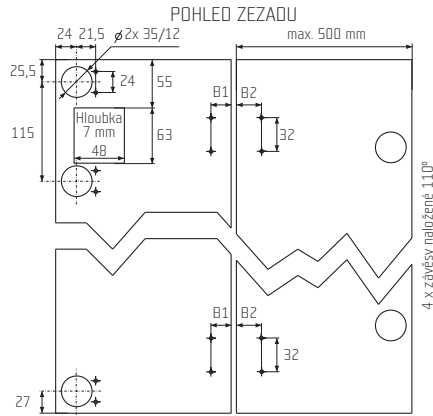

POHLED SHORA

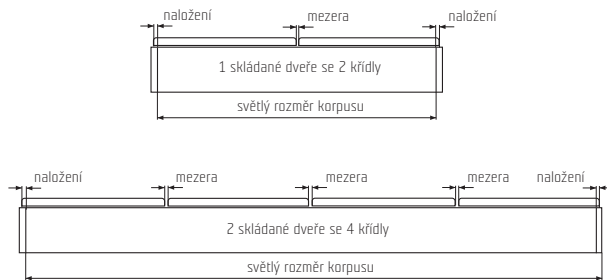

Výpočet šířky dveří a křídel pro 1 skládané dveře se 2 křídly

šířka dveří = světlá šířka korpusu + [2 x naložení]

šířka křídla = světlá šířka korpusu - (1 x mezera) + [2 x naložení] / 2

Výpočet šířky dveří a křídel pro 2 skládané dveře se 4 křídly

šířka dveří = světlá šířka korpusu + [2 x naložení]

šířka křídla = světlá šířka korpusu - (3 x mezera) + [2 x naložení] / 4

MONTÁŽNÍ SCHEMA:

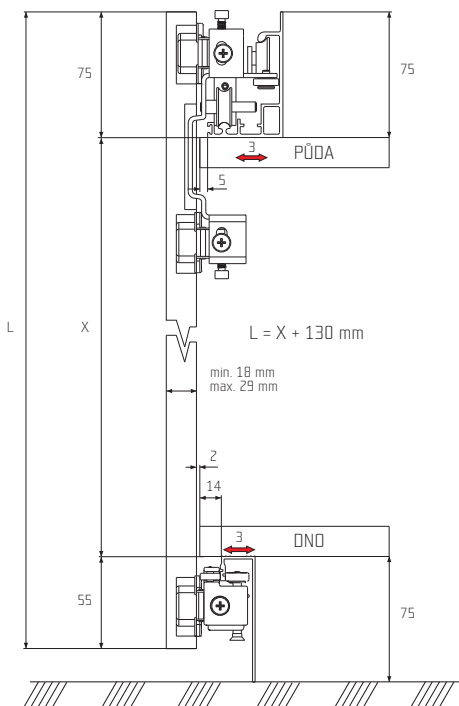

Zaoblení hran dveří a mezery  
(jako ochrana prstů)

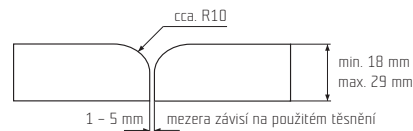

B1	20	19,5	19	18,5	18
B2	11	10,5	10	9,5	9
mezera	1	2	3	4	5



## S40SD

S40SD je kování pro skládací dveře s horním zavěšením a uchycením na bok korpusu. Je určeno zejména pro vysoké a těžké skládané dveře, uplatňuje se proto ideálně v ložnicovém i jiném nábytku. Díky zachování tzv. „čisté linie“ umožňuje montáž pojezdových lišt mimo užitný prostor skříně.

# S45

PRO POSUVNÉ  
SKŘÍŇOVÉ DVEŘI

Plynulý dotah dveří

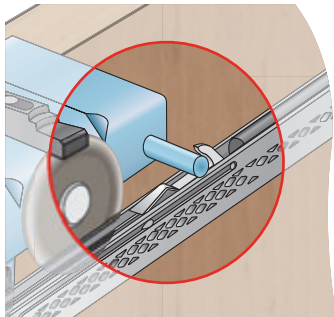

Zajištění předních dveří  
proti vypadnutí

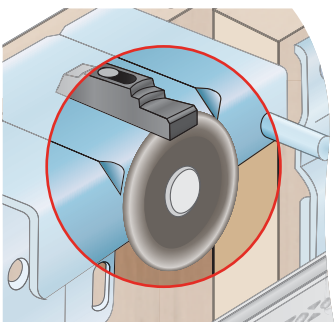

Nasazení dveří do dolního profilu  
pomocí spuštění nebo vysunutí  
dolního vozíku

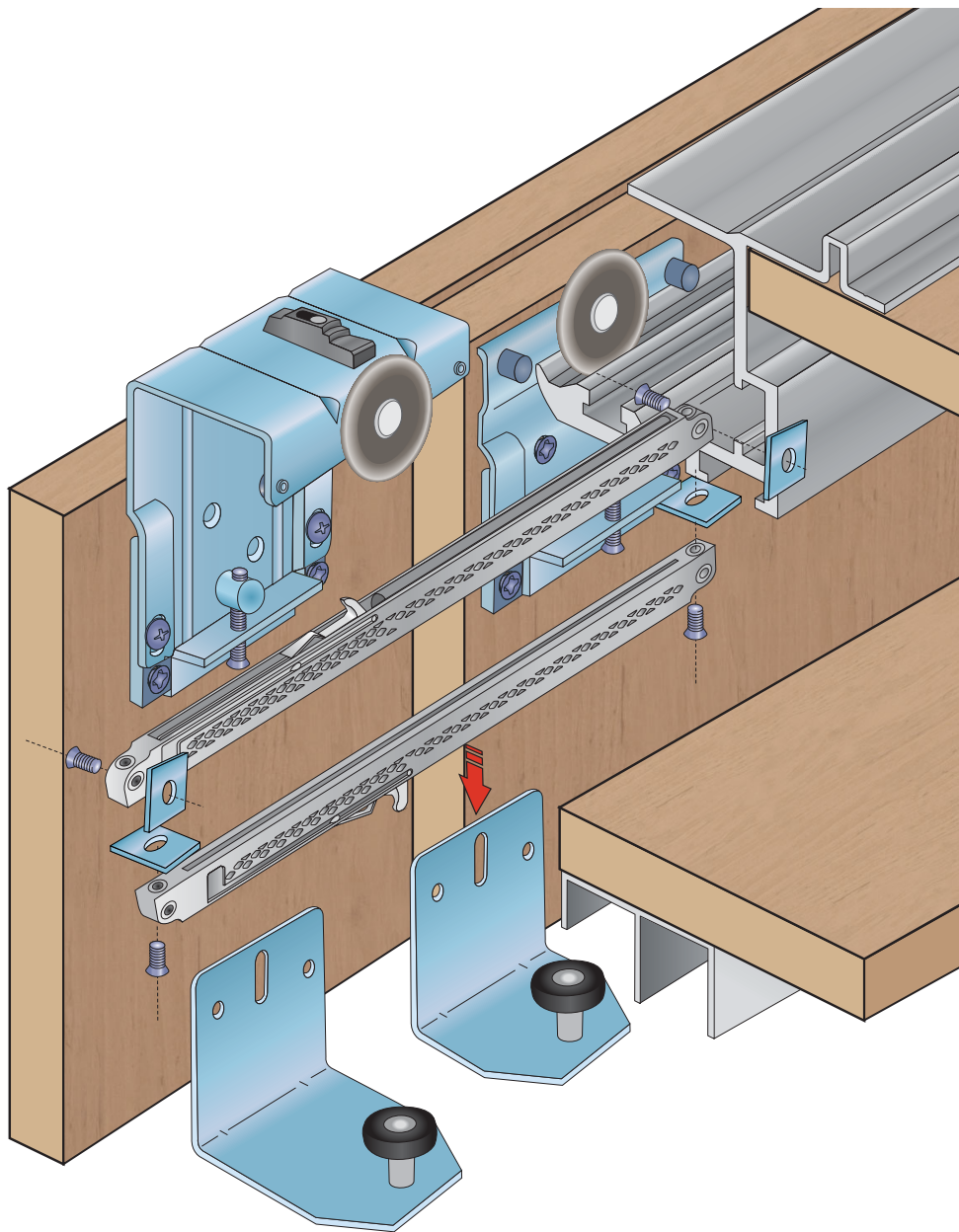
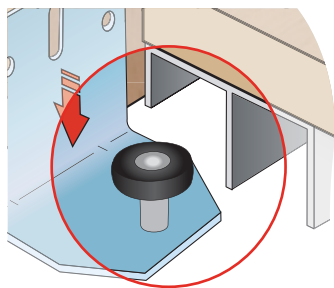

## SOUČÁSTI SYSTÉMU:

Sada S45 - Přední dveře

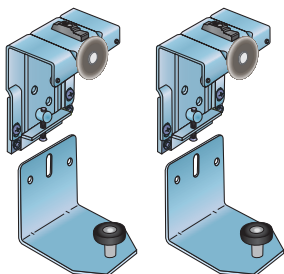

Sada S45 - Zadní dveře

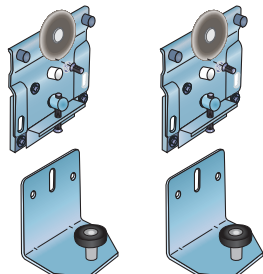

S45 - Horní profil

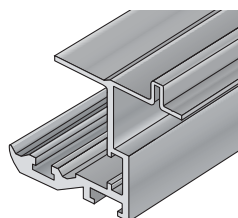

Dolní vodící profil S30/45

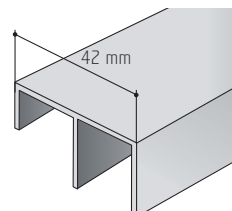



45 kg



kuličkové  
ložisko



min.  
18 mm



horní  
vedení

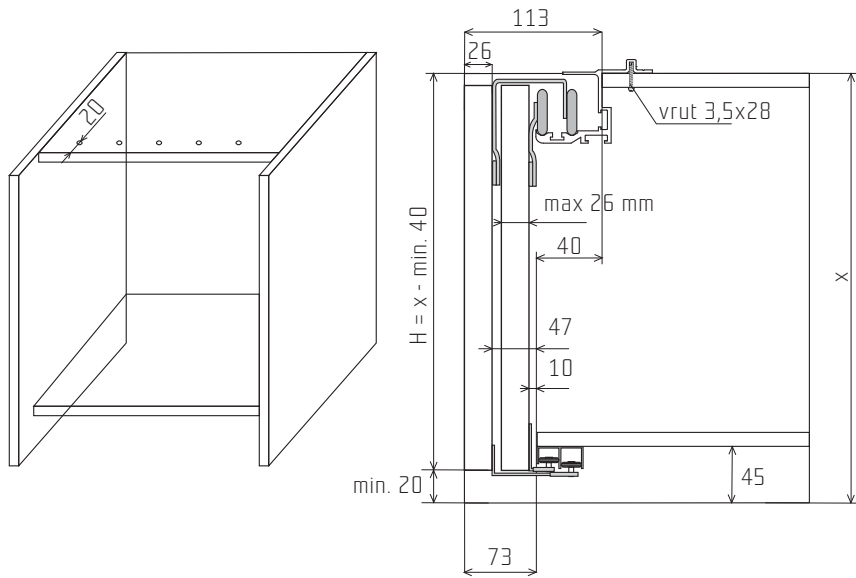

Vrtání dveří:  
(přední i zadní dveře)

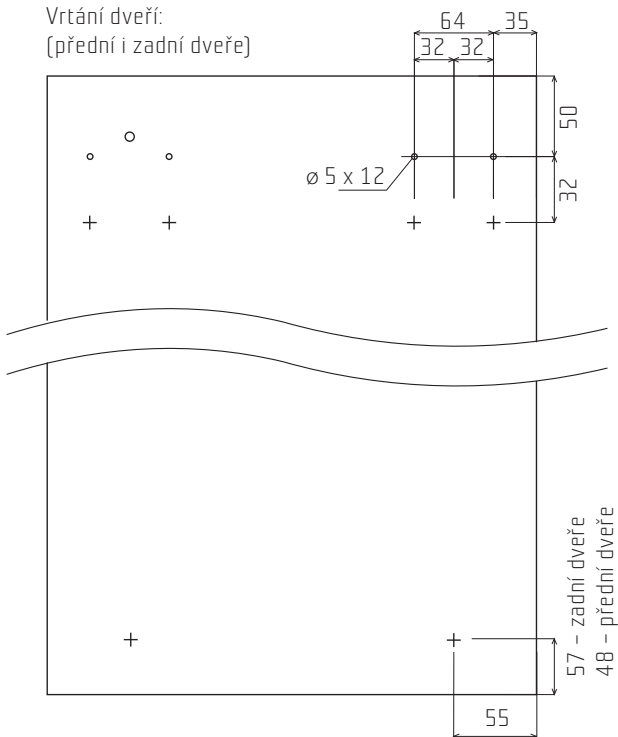

## TLUMENÍ:

Slidix T25  
pro hmotnost dveří do 25 kg



Slidix T40  
pro hmotnost dveří nad 25 kg a do 40 kg

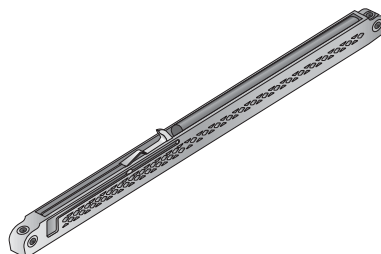

## S45

Kování S45 je určeno pro posuvné skříňové dveře. Dveře v zavřené poloze zakrývají celý posuvný mechanismus, spodní vedení je skryto pod korpusem skříně. K systému dodáváme tlumiče Slidix, které umožňují plynulý dojezd dveří.

# S50

PRO POSUVNÉ  
SKŘÍŇOVÉ DVEŘE

Montáž brzdy

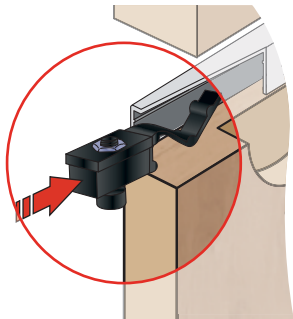

Montáž horního jezdce

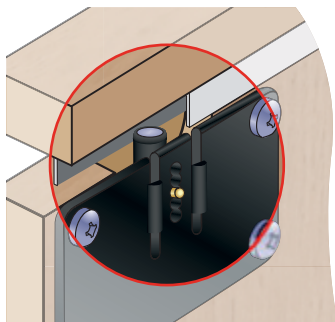

Montáž spodního jezdce

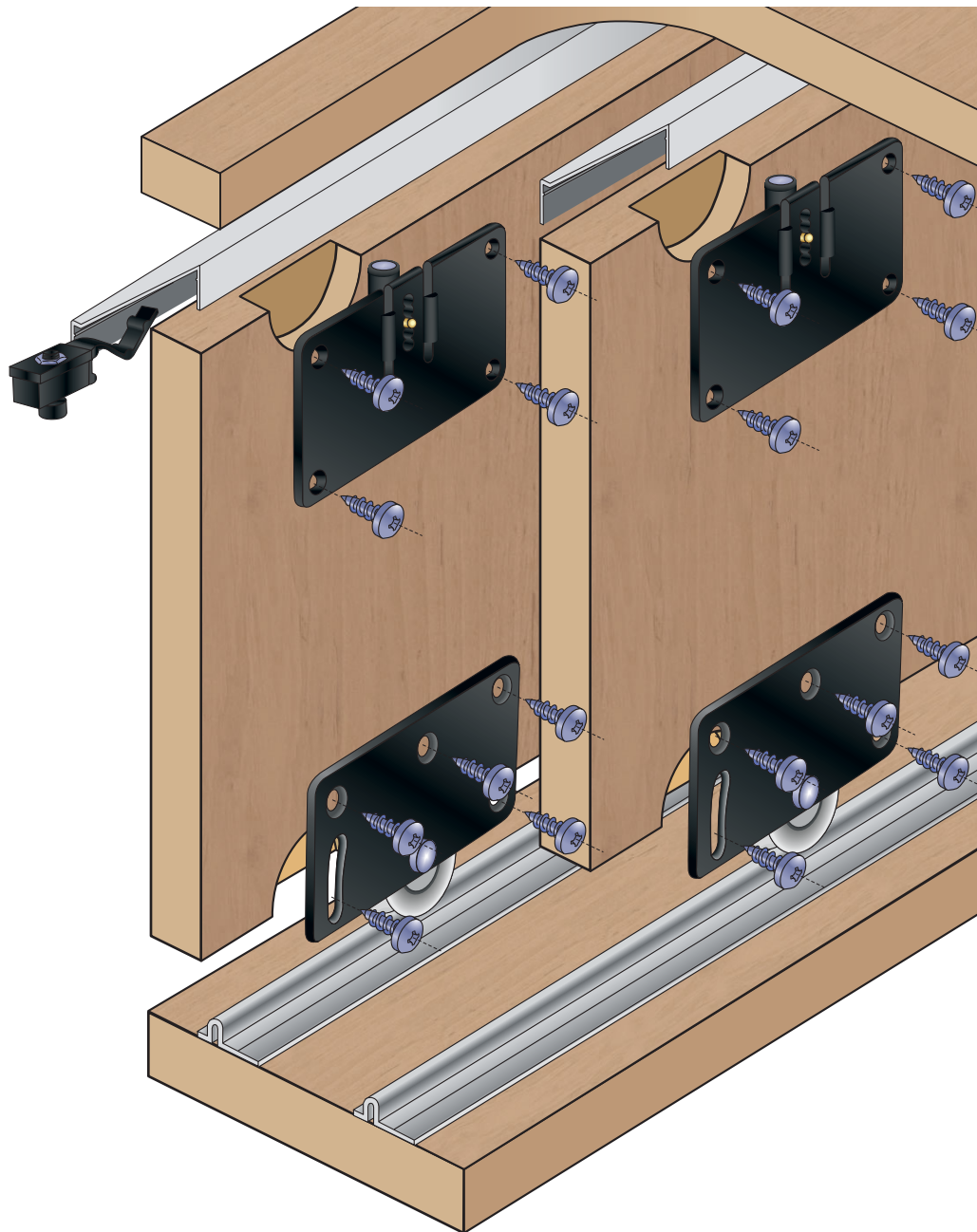
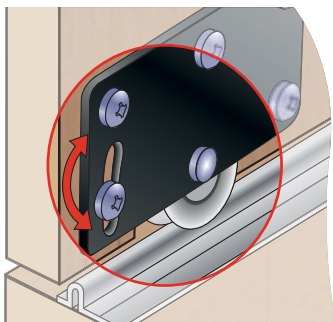

## SOUČÁSTI SYSTÉMU:

Sada S50

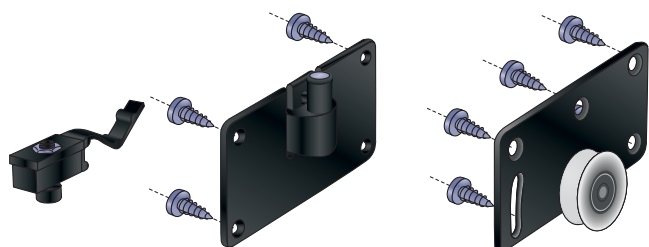

Horní profil S50

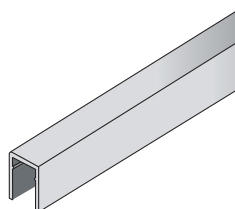

Spodní profil S50

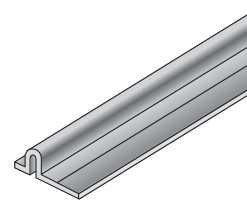





50 kg



kuličkové  
ložisko



min.  
18 mm



spodní  
vedení

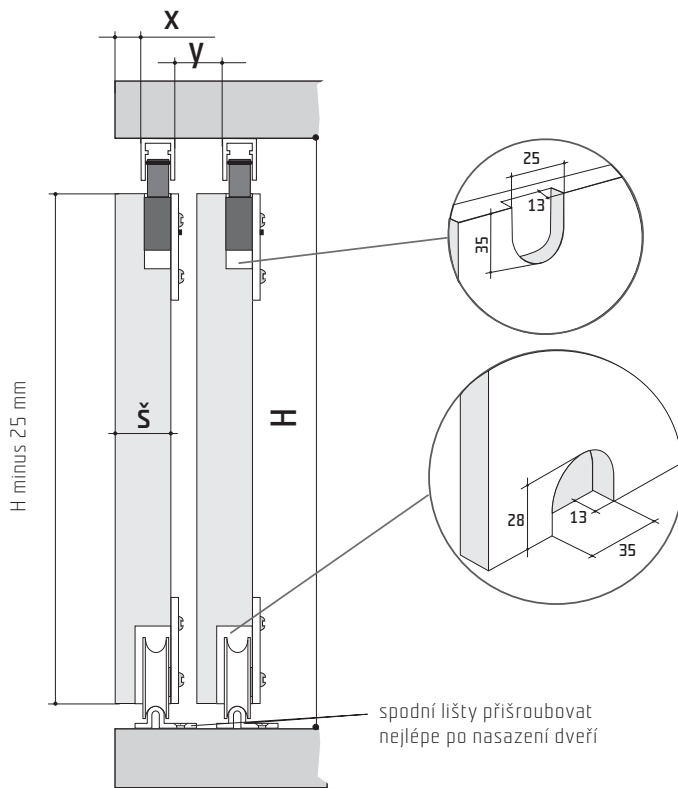

$x = s$  - maximálně 13 mm  
 $y = s$  - maximálně 7 mm

Příklad pro lamino tl. 18 mm:  
 $x = 5$  mm (dveře v rovině s korpusem)  
 $y =$  minimálně 11 mm

Montáž lišt:

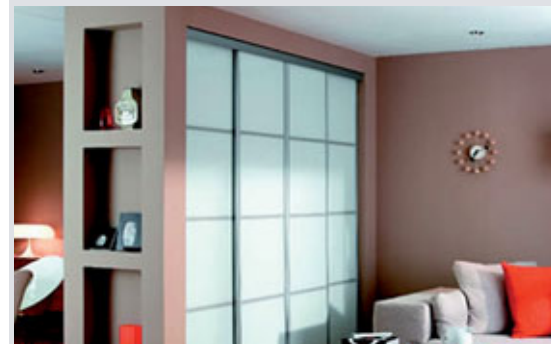
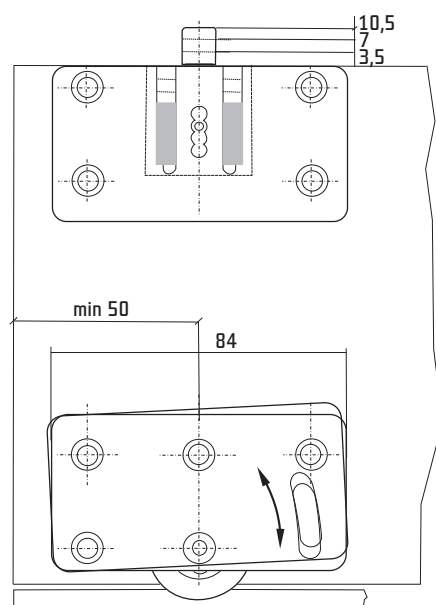
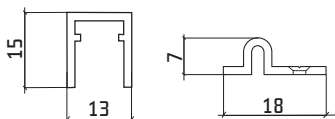

## S50

Kování S50 je určeno pro posuvné dveře ve skříních. Výhodou je jednoduchá montáž a jednoduché výškové seřízení. Vodicí profily jsou buď ze surového nebo v případě spodních profilů z eloxovaného hliníku.

Kování se vyznačuje především:

- jednoduchým nasazením dveří pomocí posuvné kladky
- tichým chodem

# S50N

PRO POSUVNÉ  
SKŘÍŇOVÉ DVEŘE

Montáž horního jezdcce

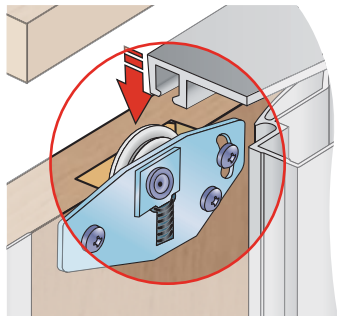

Montáž brzdy

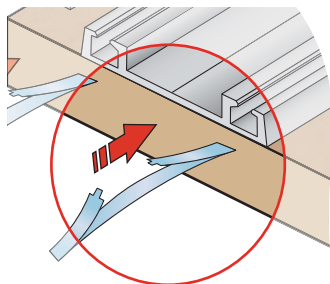

Montáž spodního jezdcce

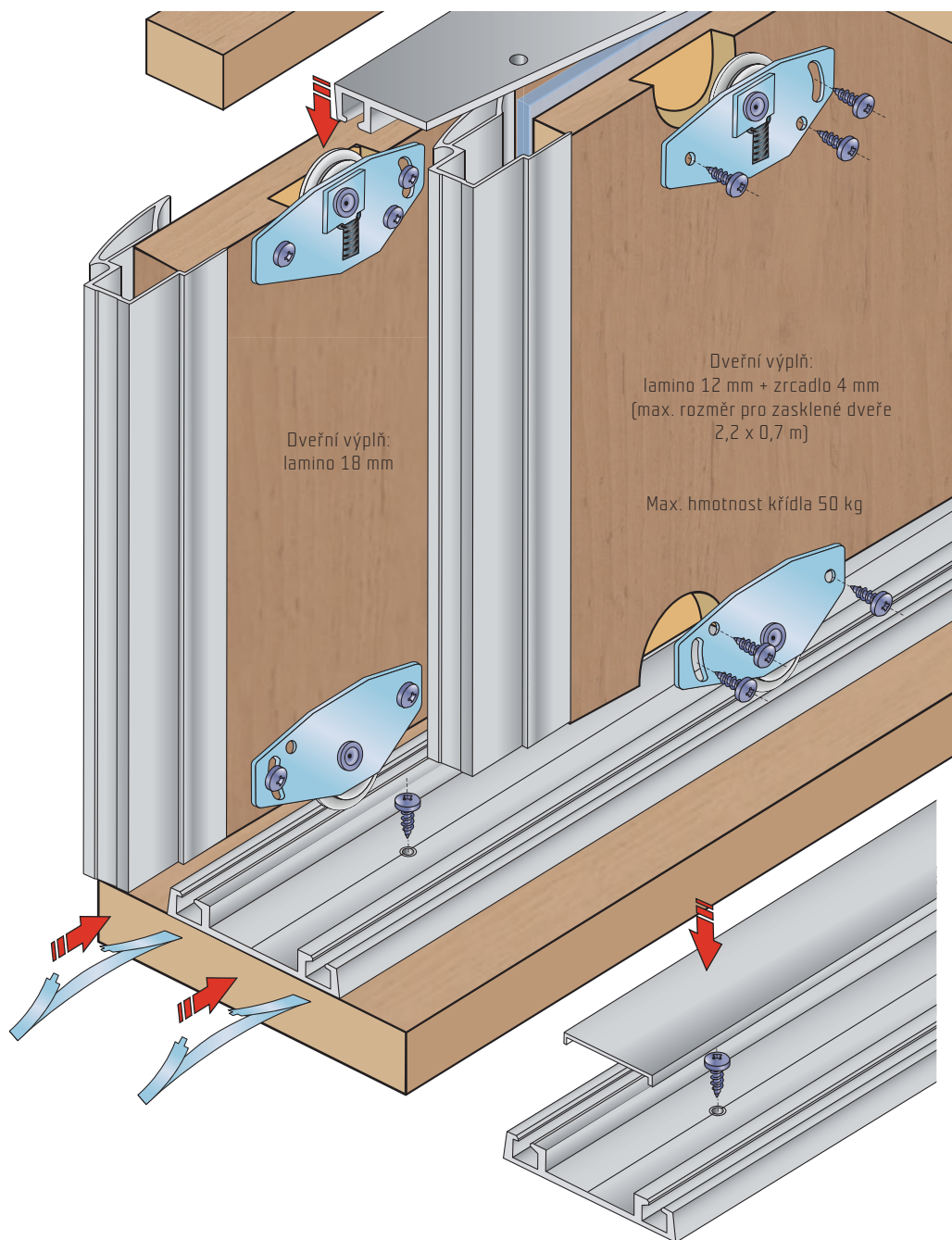
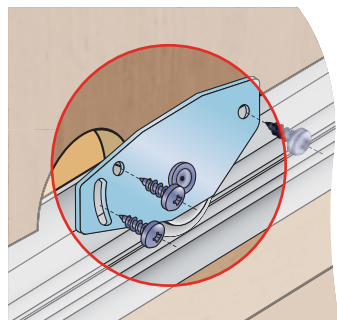

## SOUČÁSTI SYSTÉMU:

Sada S50N

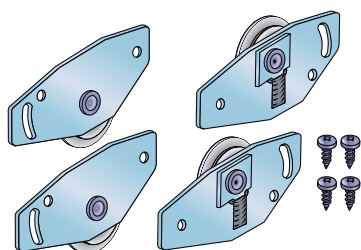

Profil S06N

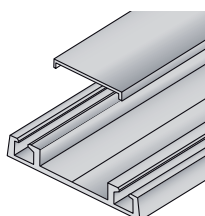

Profil S06N-1

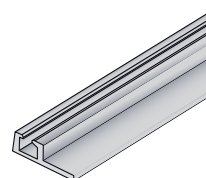



50 kg



kuličkové  
ložisko



4 mm  
18 mm



spodní  
vedení

s profily S06N:

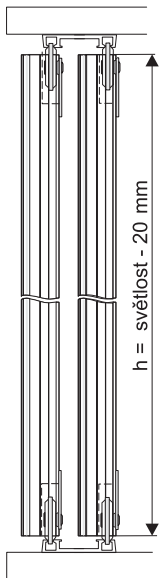

s profily S03:

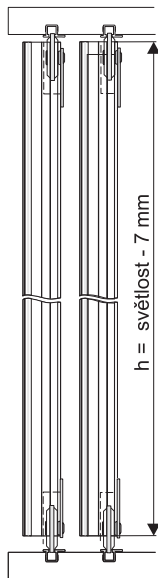

Dveřní křídlo nasazujeme nejprve do spodní kolejničky a následným stlačením kolečka horního vozíku zasadíme do horní kolejničky.

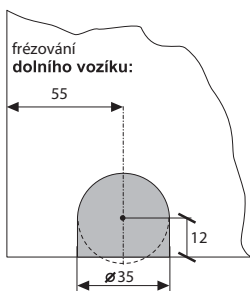
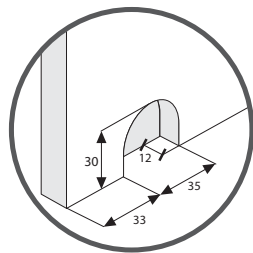
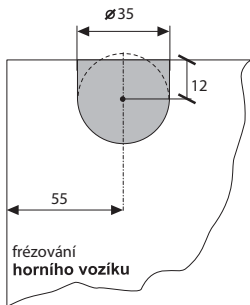

Do systému lze použít boční madla: S04, S08, S09, S10, S11, S12, S13, S14

Profil S03

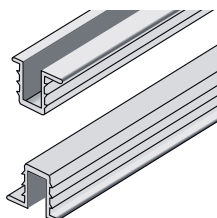

Brzda S06N

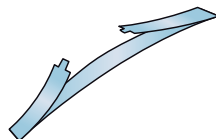

## S50N

Kování S50N je určeno pro menší šatní skříně, ve kterých je jako materiál dveří použito lamino, masiv popř. pro dvířka z hliníkových profilů. Pojezdové vozíky se zafrézovávají do materiálu dveří. Horní vozík má odpružené kolečko, což zabezpečuje jednak snadné nasazení dveří při montáži ale i bezpečný chod dveří.

# S55

PRO POSUVNÉ  
SKŘÍŇOVÉ DVEŘE

Montáž horního vozíku

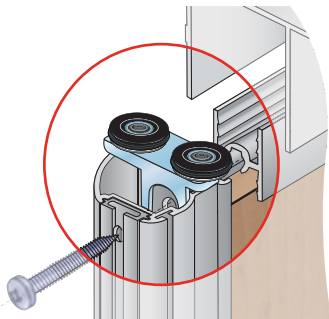

Dvevní výplň: sklo, zrcadlo 4 mm  
nebo bezpečnostní sklo 4 mm

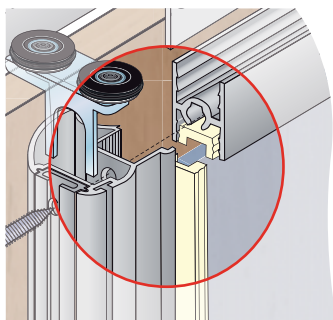

Možnost použití profilu S06N  
a krycího profilu S06N

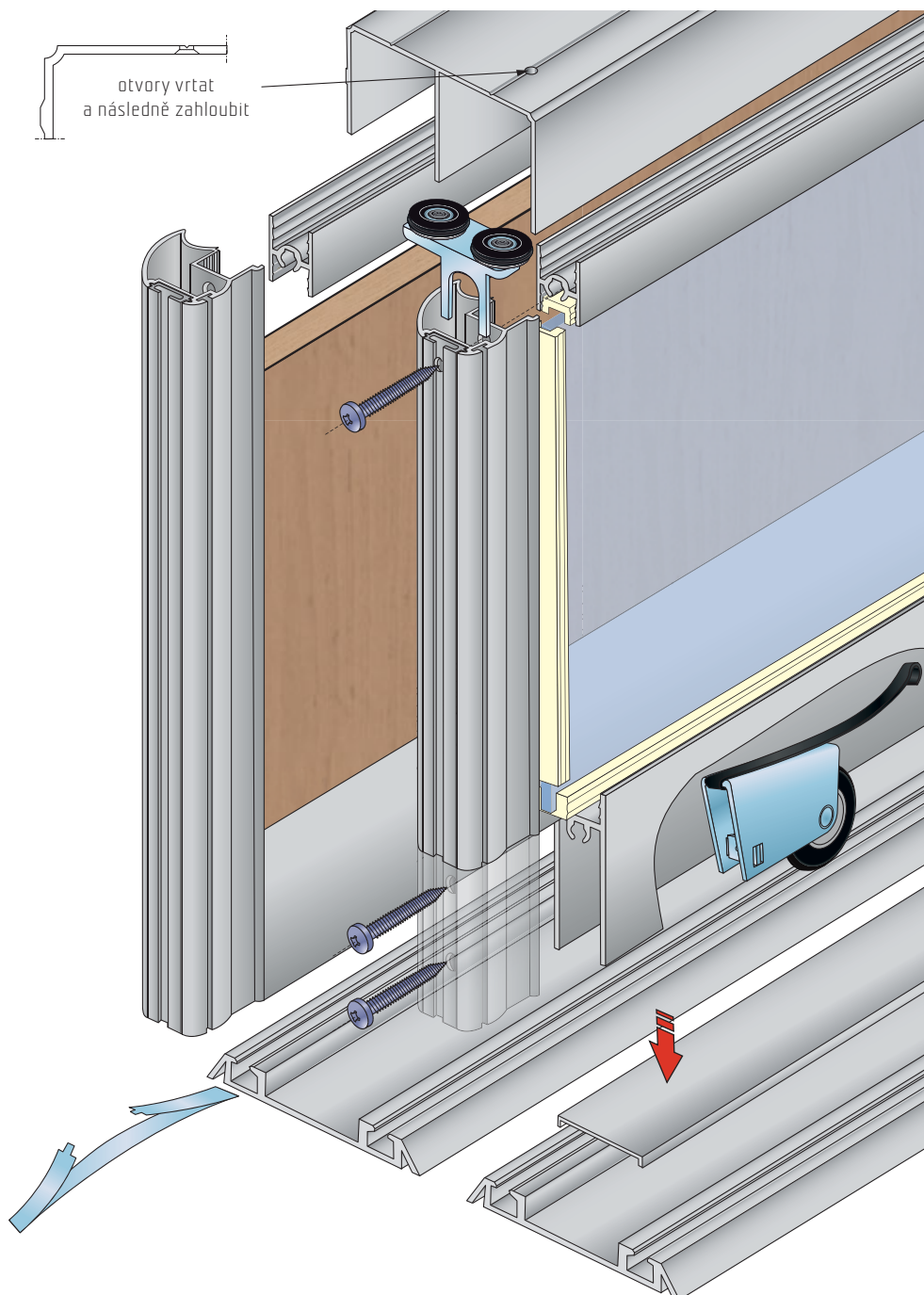
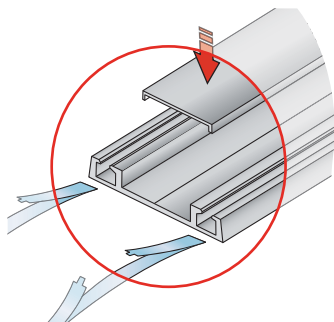

## VODÍCÍ PROFILY:

Profil S05

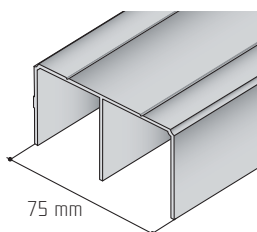

Profil S06NN  
krycí profil S06N

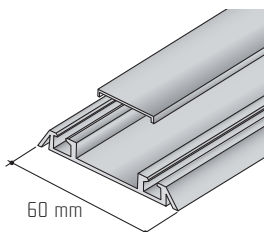

Profil S06N  
krycí profil S06N

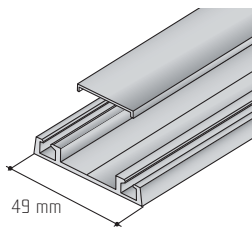

Profil S05-1

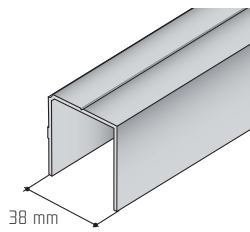

Profil S06N-1

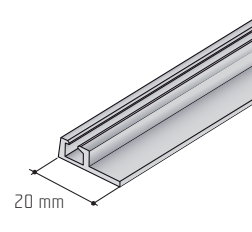



55 kg



kuličkové  
ložisko



4 mm  
10 mm



spodní  
vedení

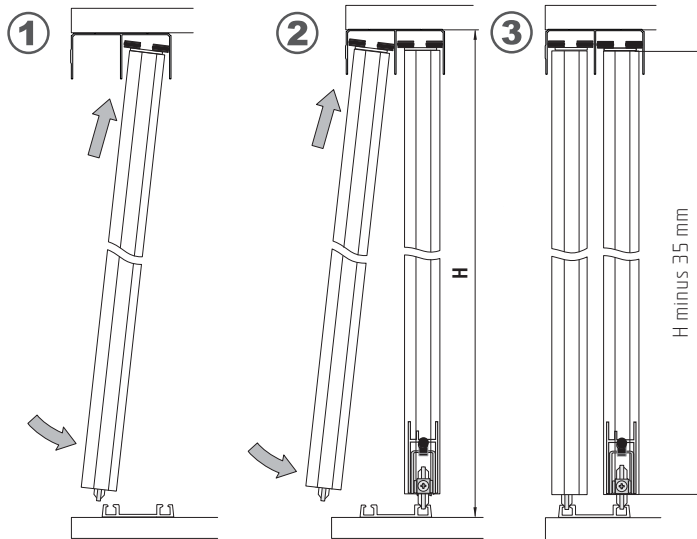

## PŘÍČKY:

S55 horní a středová příčka

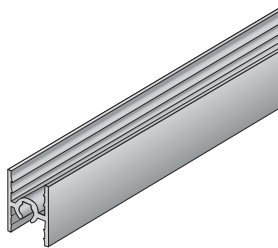

S55 dolní příčka

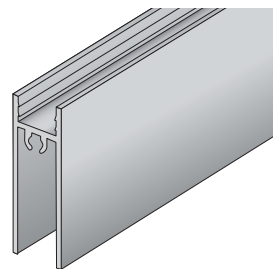

## SVISLÉ PROFILY:

Madlo S15

34 mm

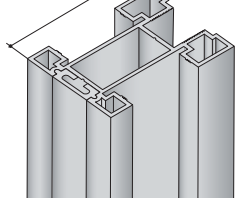

Madlo S16

40 mm

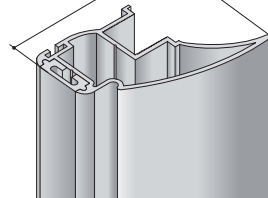

Madlo S17

27,3 mm

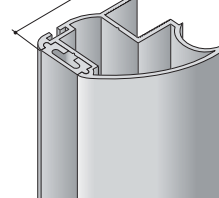

Madlo S18

30 mm

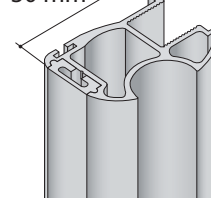

## KOVÁNÍ, TĚSNĚNÍ:

Sada S55A  
(pro madlo S15)

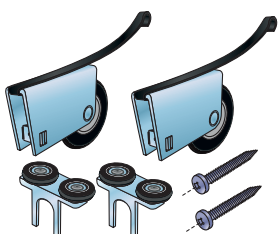

Sada S55B  
(pro madla S16, S17, S18)

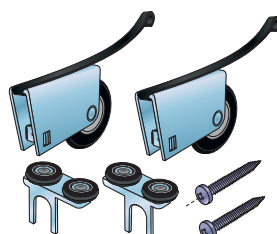

Brzda S06N

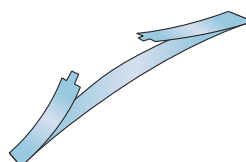

Těsnění pro sklo  
tl. 4 mm



Těsnění pro sklo  
tl. 6 mm



## S55

Systém S55 je určen pro použití se sklem tl. 4 mm a 6 mm nebo s plošnými materiály tl. 10 mm.

Vyrábí se ve variantách stříbrný elox, světlý bronz a tmavý bronz. Horní vozíky mají ložisková kolečka s gumovou obručí, což zaručuje velmi tichý chod. Spodní vozíky mají ložisková kolečka s obručí z vysoce odolného plastu.

# S60

PRO VESTAVĚNÉ  
SKŘÍŇĚ

Ovevní výplň: lamino 18 mm

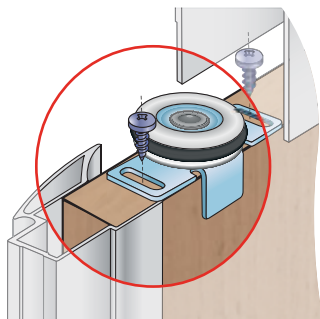

Ovevní výplň:  
lamino 12 mm + zrcadlo 4 mm  
(max. rozměr pro zasklené  
dveře 2,2 x 0,7 m)

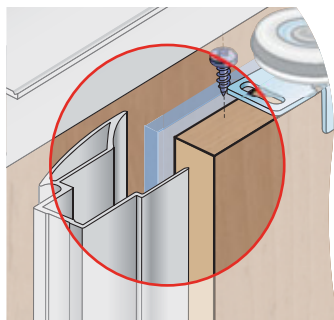

Montáž brzdy

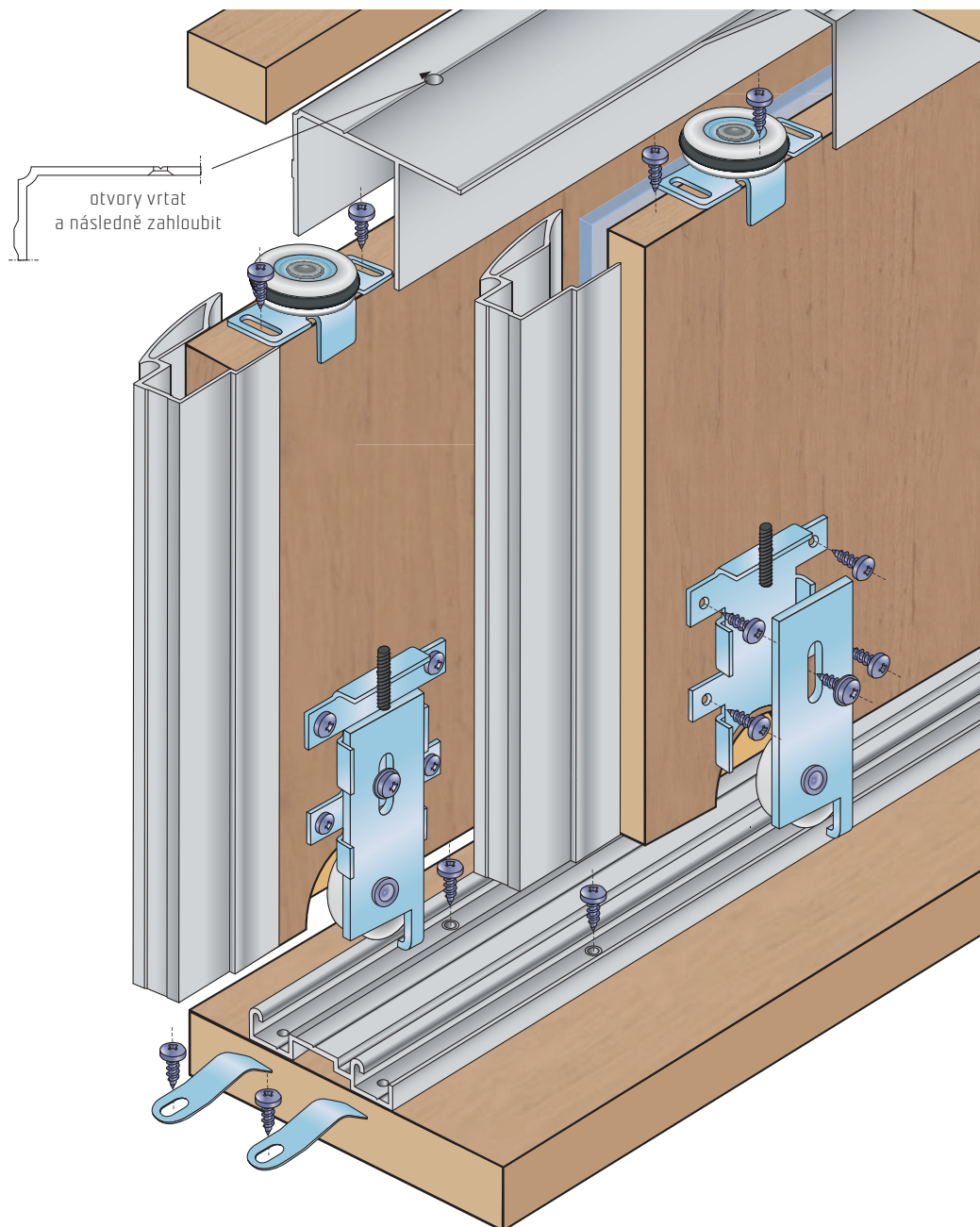
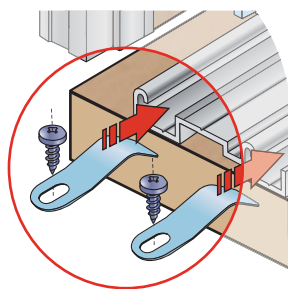

## SOUČÁSTI SYSTÉMU:

Sada S60

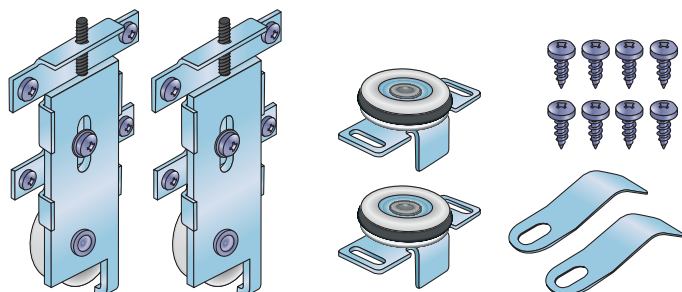

Horní profil S05

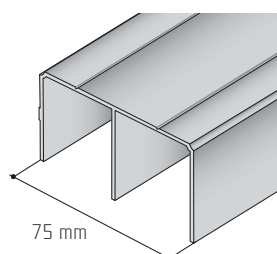

Spodní profil S06

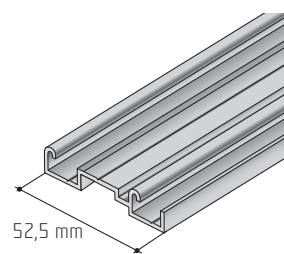



60 kg



kuličkové ložisko



spodní vedení

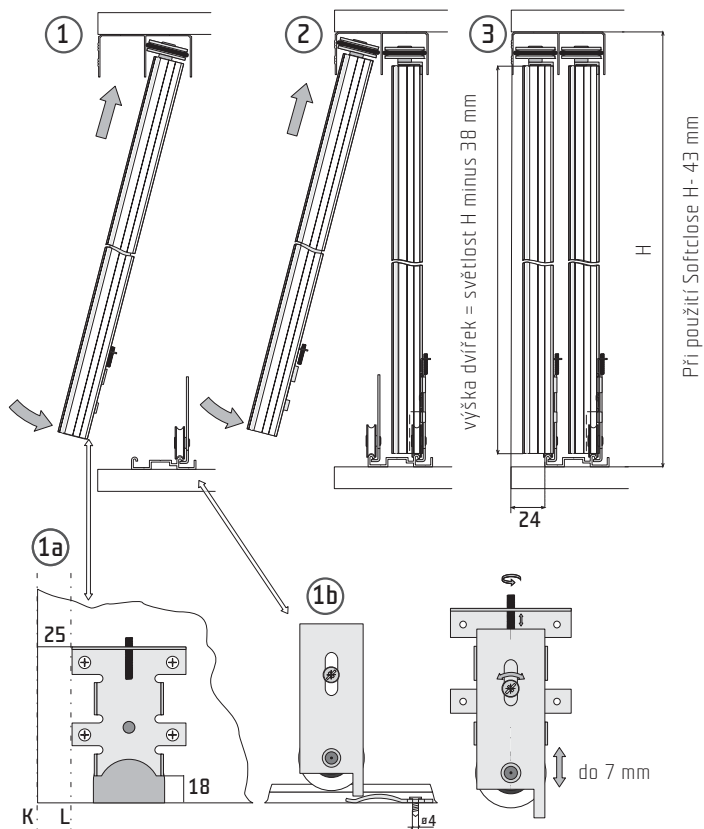

Pozor: Při montáži pevné části vozíku dbejte na to, aby osy K a L byly rovnoběžné.

otvory vrtat na  $\varnothing 3$  mm a následně zahлубit vrtákem  $\varnothing 7$  mm

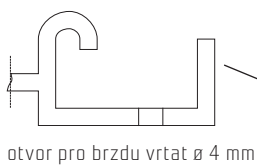
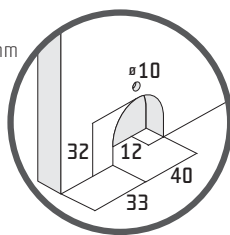
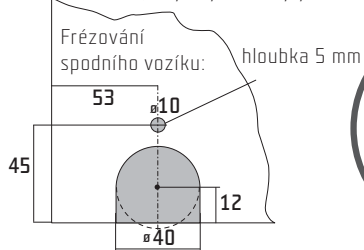

otvor pro brzdou vrtat  $\varnothing 4$  mm

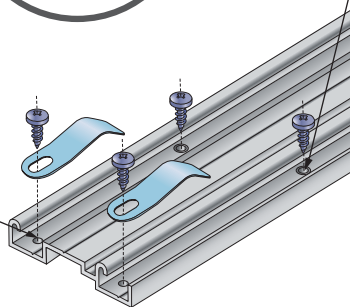

Profil S04

Profil S04N

Profil S08

Profil S12

Profil S13

Profil S14

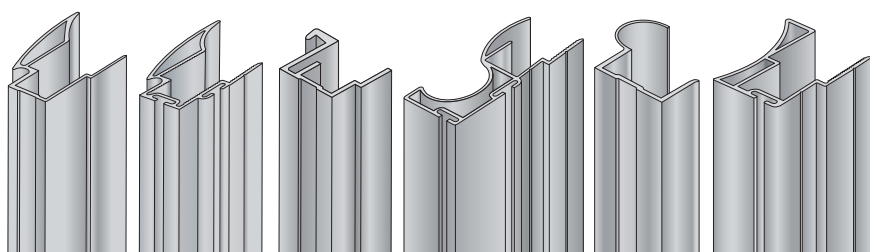

## S60

Stále více domácností hledá možnost, jak za přijatelnou cenu řešit problém s úložným prostorem a řešení se nabízí ve formě vestavěných skříní. Jejich cena však zatím převyšuje na našem trhu možnosti velké části rodin. Proto jsme začali dodávat kování pro vestavěné skříně S60. Jeho montáž může provádět jak odborník tak i domácí kutil, výsledný efekt bude srovnatelný s mnohem dražšími systémy dveří na míru.

V kombinaci s námi dodávanými madly bude potom tento efekt špičkový.

# S60N

PRO VESTAVĚNÉ  
SKŘÍŇĚ

Montáž horního vodícího vozíku

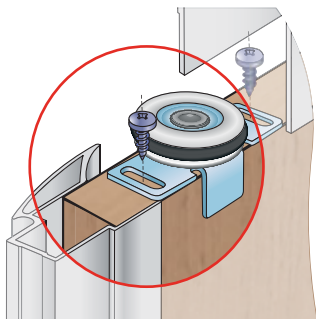

Dveřní výplň:  
lamino 12 mm + zrcadlo 4 mm  
(max. rozměr pro zasklené  
dveře 2,2 x 0,7 m)

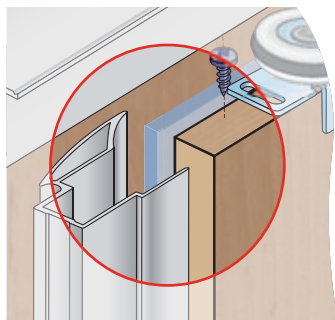

Možnost použití profilu S06NN  
a krycího profilu S06NN viz str. 36

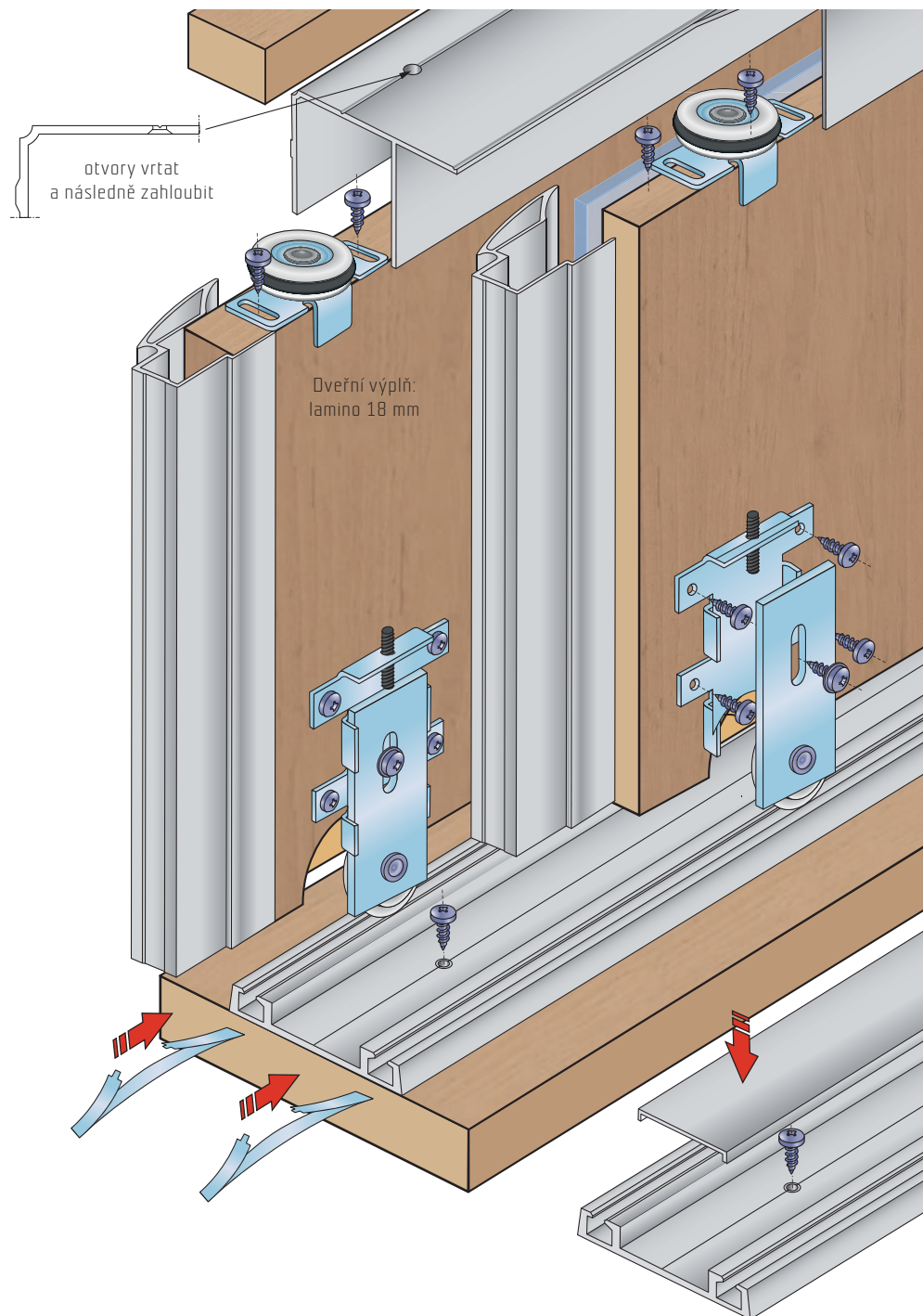
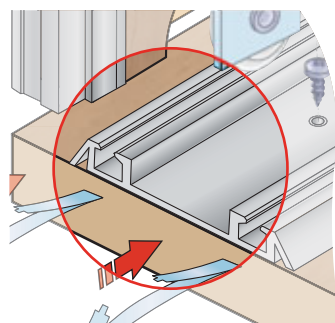

## SOUČÁSTI SYSTÉMU:

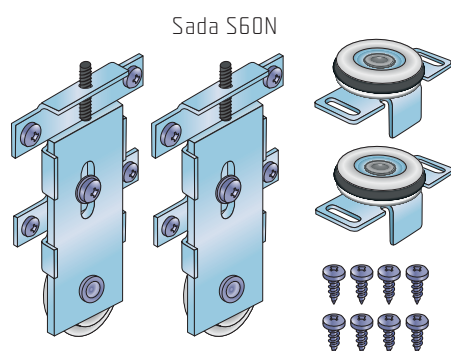

Brzda S06N

Horní profil S05

Krycí profil S06N  
Spodní profil S06N





60 kg



kuličkové  
ložisko



spodní  
vedení

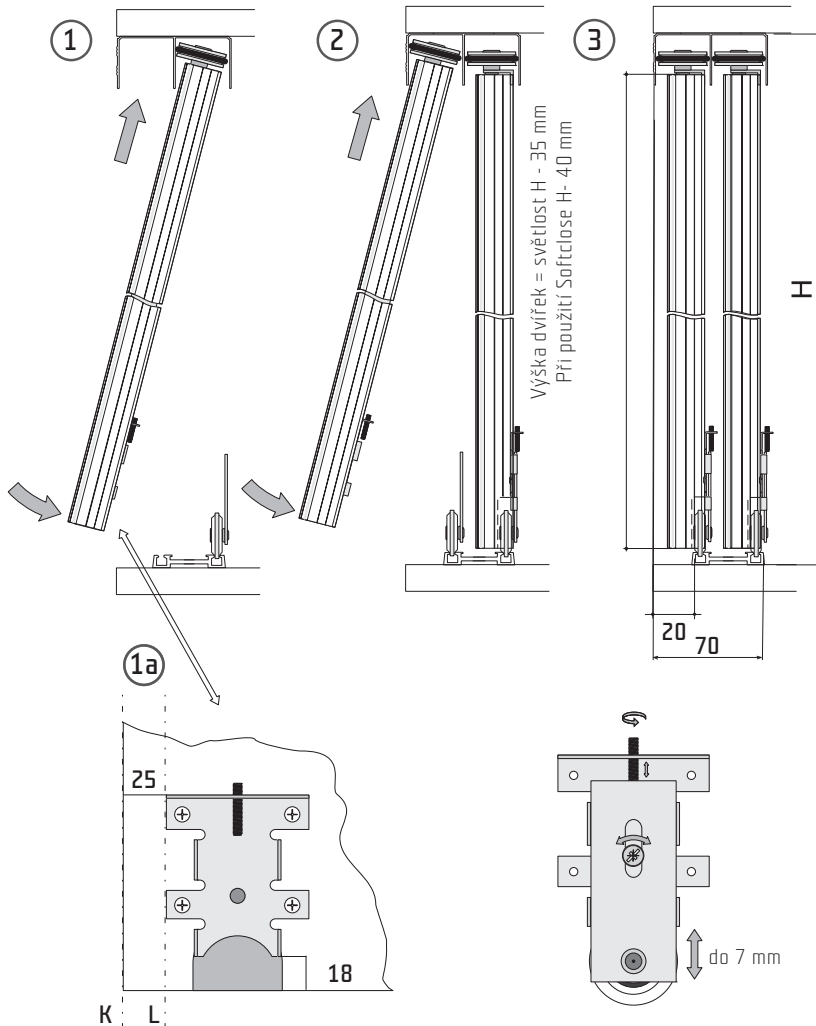

Pozor: Při montáži pevné části vozíku dbejte na to, aby osy K a L byly rovnoběžné.

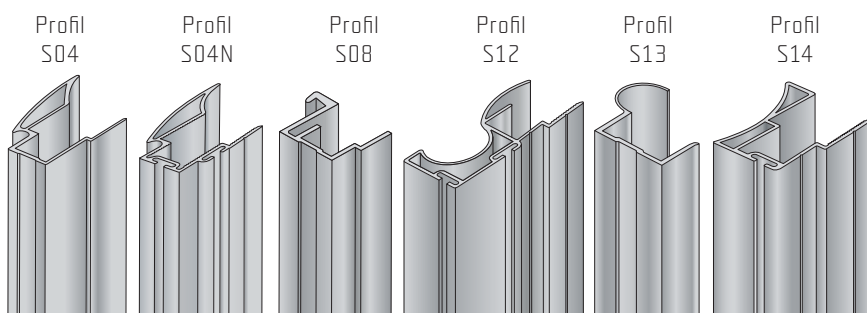
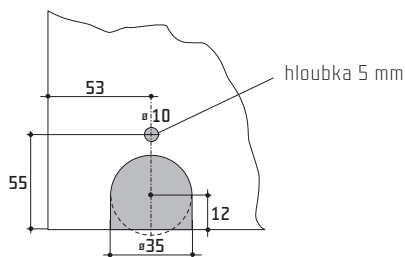

## S60N

Kování S60N je vylepšenou verzí kování S60. Změna spočívá v nové spodní vodící liště a v promyšleném systému aretace dveří. Spodní brzda může být použita pro aretaci průchozích i krajních dveří.

# S60H

PRO POSUVNÉ  
SKŘÍŇOVÉ DVEŘE

Montáž brzdy  
(před montáží profilu)

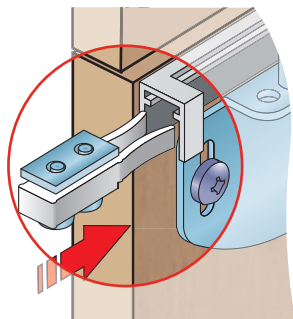

Výškové seřízení dveří

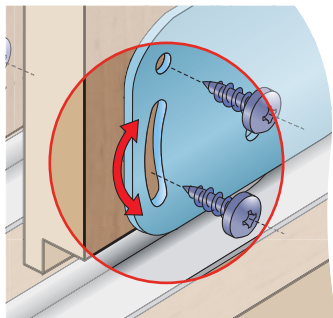

Detail horního vozíku

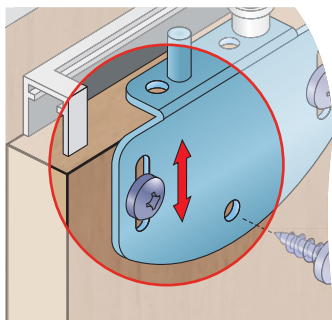

Kování je shodné s kováním H60

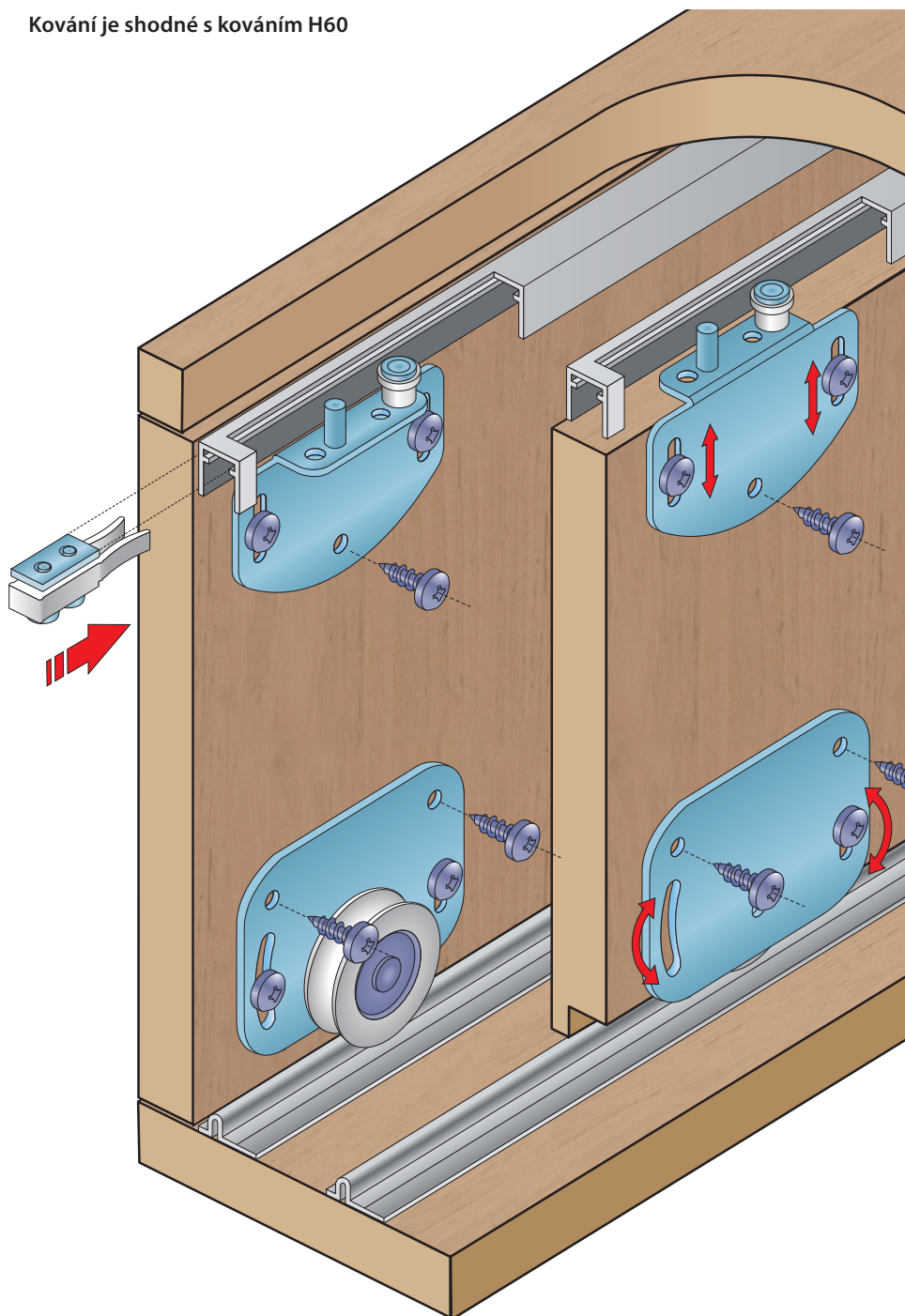

## SOUČÁSTI SYSTÉMU:

Sada S60H

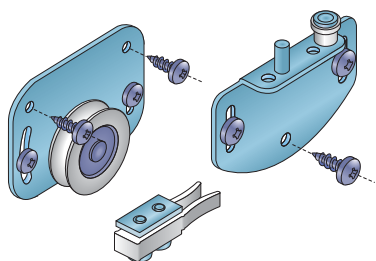

Horní profil S50

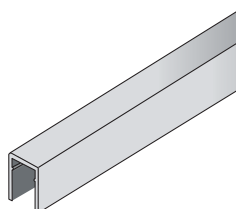

Profil S50

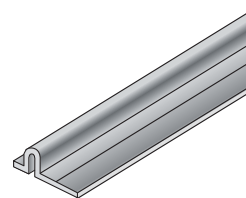



60 kg



kuličkové  
ložisko



min.  
16 mm



spodní  
vedení

### MONTÁŽNÍ SCHEMA

VAR. 1

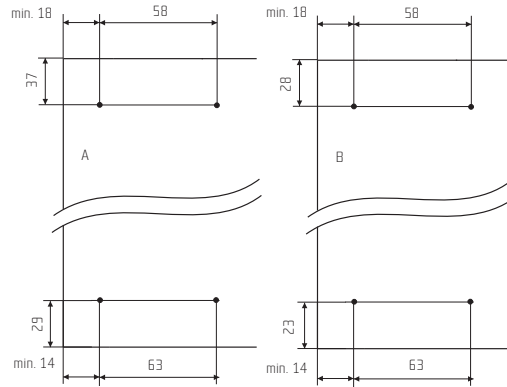
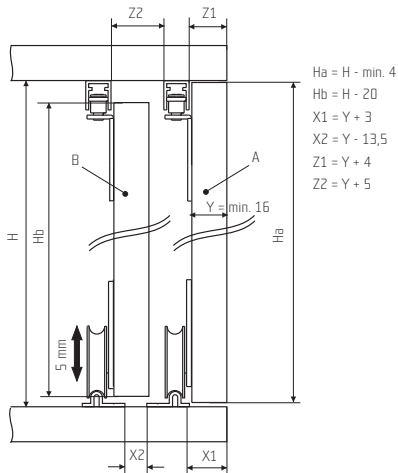

VAR. 2

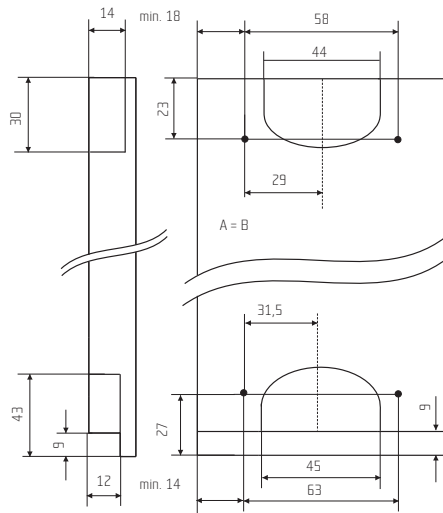
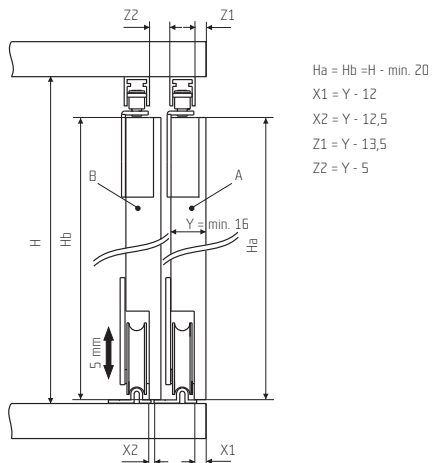

VAR. 3

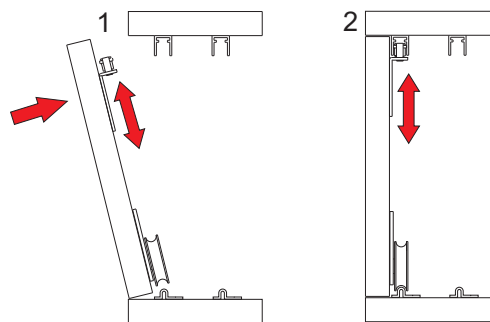
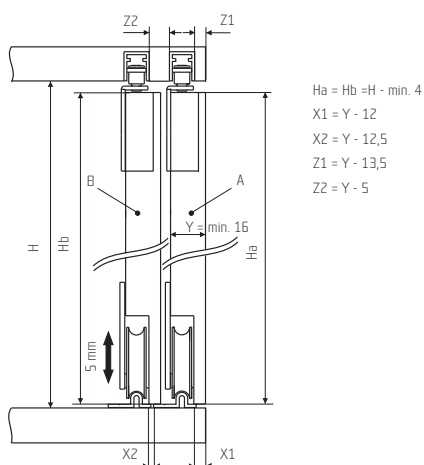

1. Vozíky se uchyťí na dveře dle výše uvedeného vrtacího plánu. Horní vozíky jsou přítom v dolní poloze.
2. Dveře se zasunou dolními vozíky do dolní lišty, horní vozíky se zasunou do horní lišty a dotáhnou vruty.
3. Po výškovém seřízení dveří se poloha dveří zafixuje zajišťovacími vruty.



## S60H

Nábytkové kování S60H se používá pro větší vložené skříňové dveře. Systém se vyznačuje lehkým a tichým chodem. Kování je určeno pro laminovou nebo dřevěnou výplň od tl. 16 mm. Vodicí profily jsou k dispozici jak v eloxovaném hliníku, tak v levnější surové variantě.

# S65

PRO VESTAVĚNÉ  
SKŘÍŇĚ

## Montáž horního vozíku

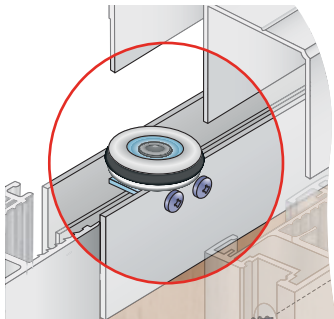

Ovevní výplň: zrcadlo 4 mm  
nebo bezpečnostní sklo 4 mm

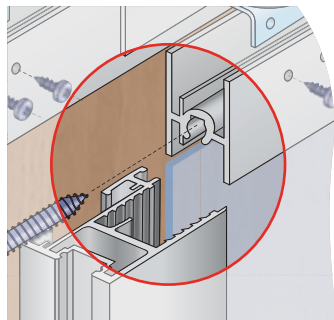

Možnost použití profilu S06N  
a krycího profilu S06NN viz str. 32

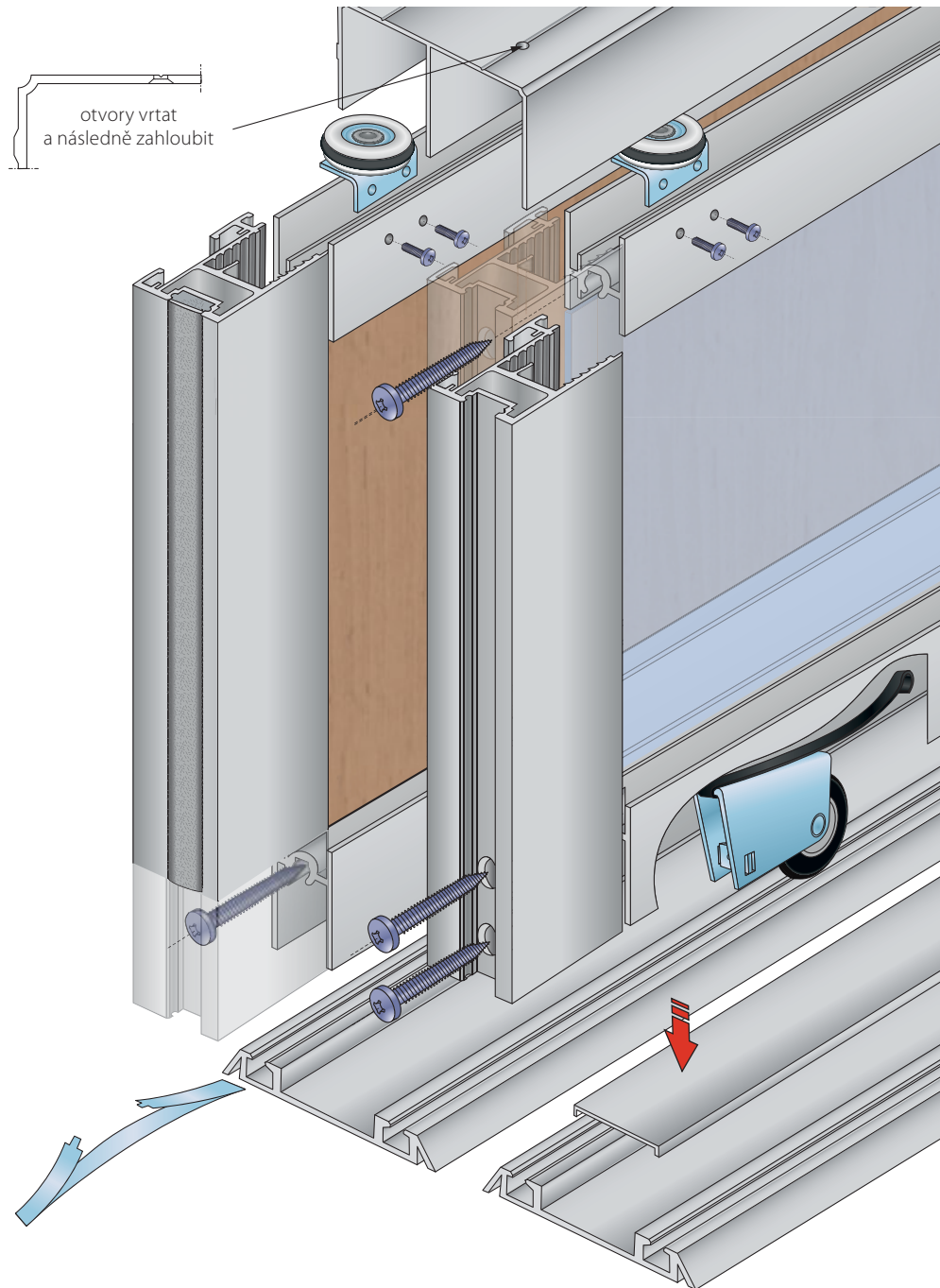
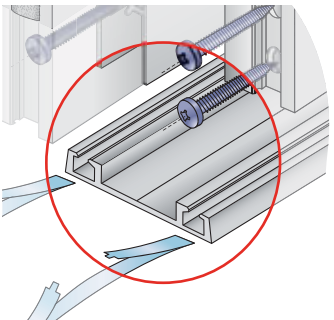

## SOUČÁSTI SYSTÉMU:

Sada S65

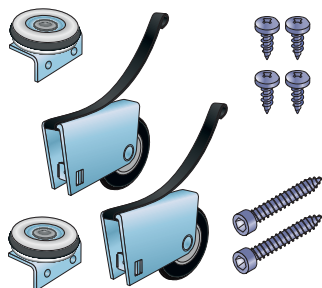

Brzda S06N

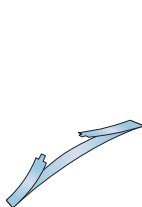

Příčky S65

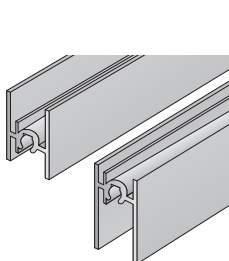

Profil S05

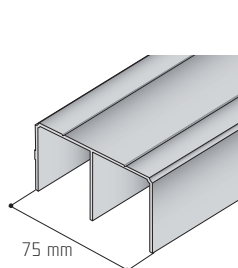

Krycí profil S06NN  
Profil S06NN

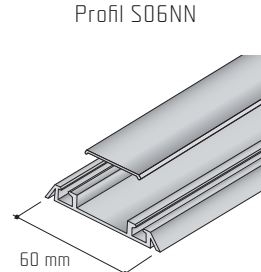



65 kg



kuličkové ložisko



4 mm  
18 mm



spodní vedení

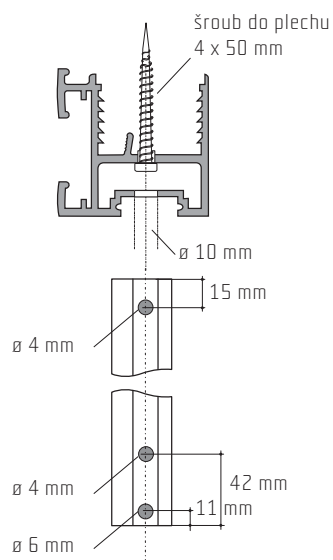
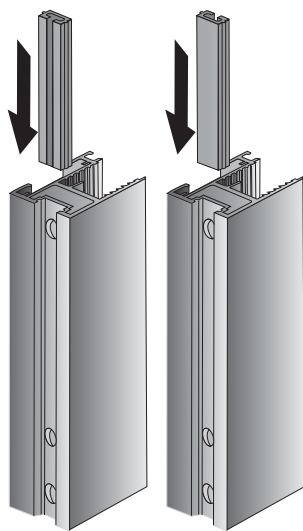
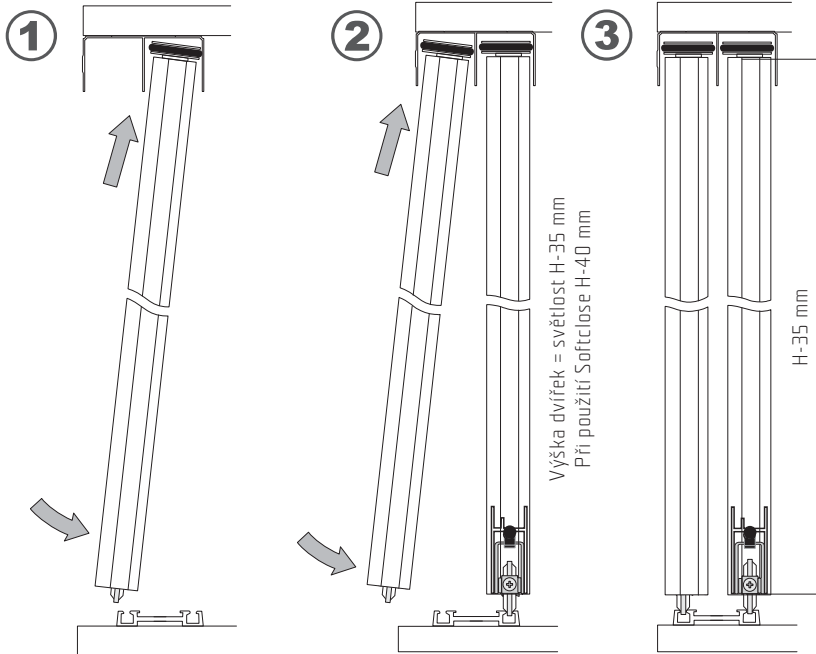

## S65

System je určen pro stavbu vestavěných skříní. Umožňuje použití výplně 18 mm (LTD 18 mm) a skla tl. 4 mm. Úchytkový profil S10 a S11 se prodává včetně krycího profilu, kterým se po montáži zakryjí spojovací šrouby rámu a seřizovací šroub kování. Madlo S10 dále umožňuje vsunutí olepovací pásky (běžné šířky 22 mm), kterou se dá celkový efekt dveří doladit.

Všechny profily systému dodáváme v barvách:

- stříbrný hliník (mat)
- světlý bronz
- tmavý bronz

Profil S09 a krycí profil

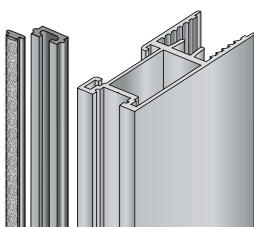

Profil S10 a krycí profil

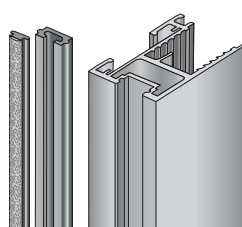

Profil S11 a krycí profil

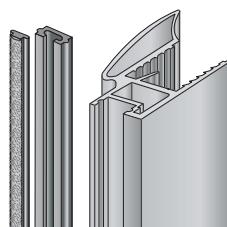

# S80/S80SC

PRO INTERIÉROVÉ  
DVEŘE

Montáž bočního úchytu

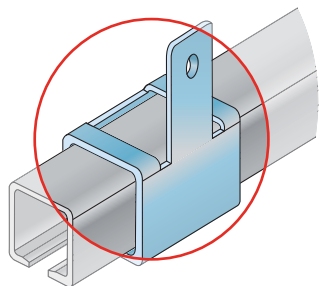

Montáž horního úchytu

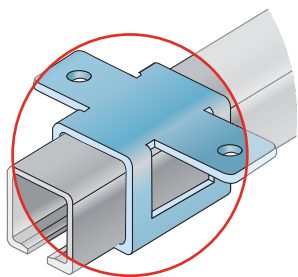

Montáž vozíku

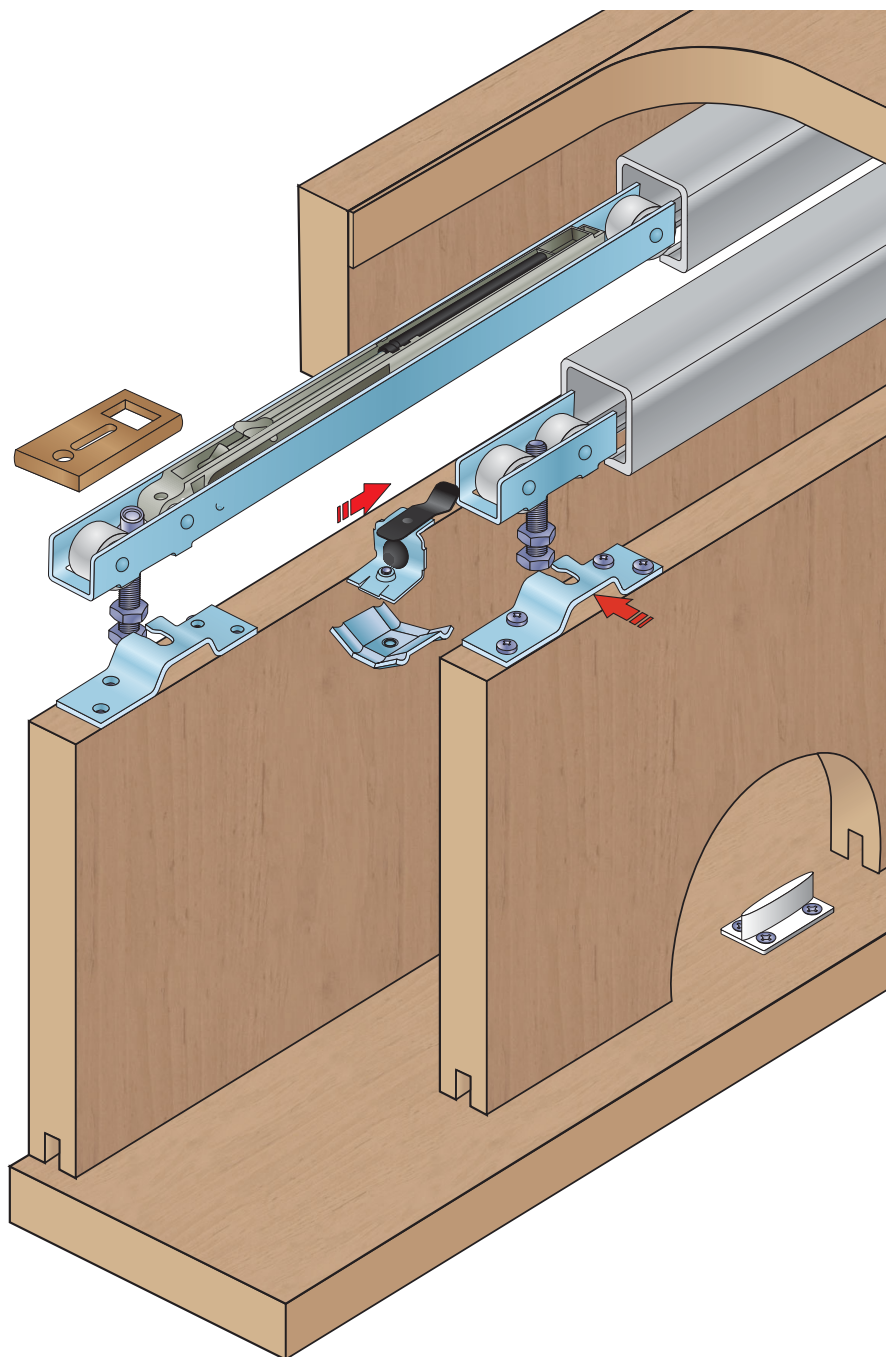
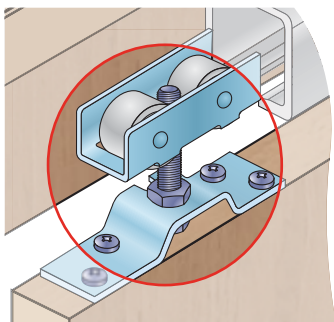

## SOUČÁSTI SYSTÉMU:

Sada S80

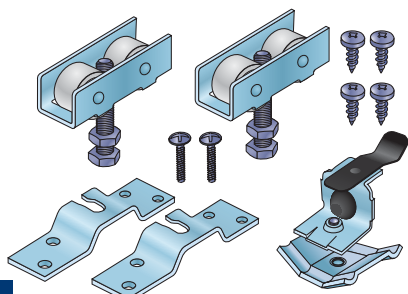

Profil S40/S80 Hliník | Profil S40/S80 ocel

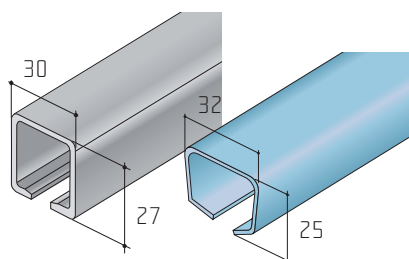

Úchyt lišty boční

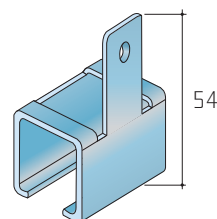

Úchyt lišty horní

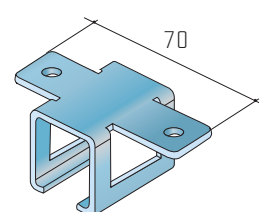



80 kg



kuličkové  
ložisko



min.  
18 mm



horní  
vedení

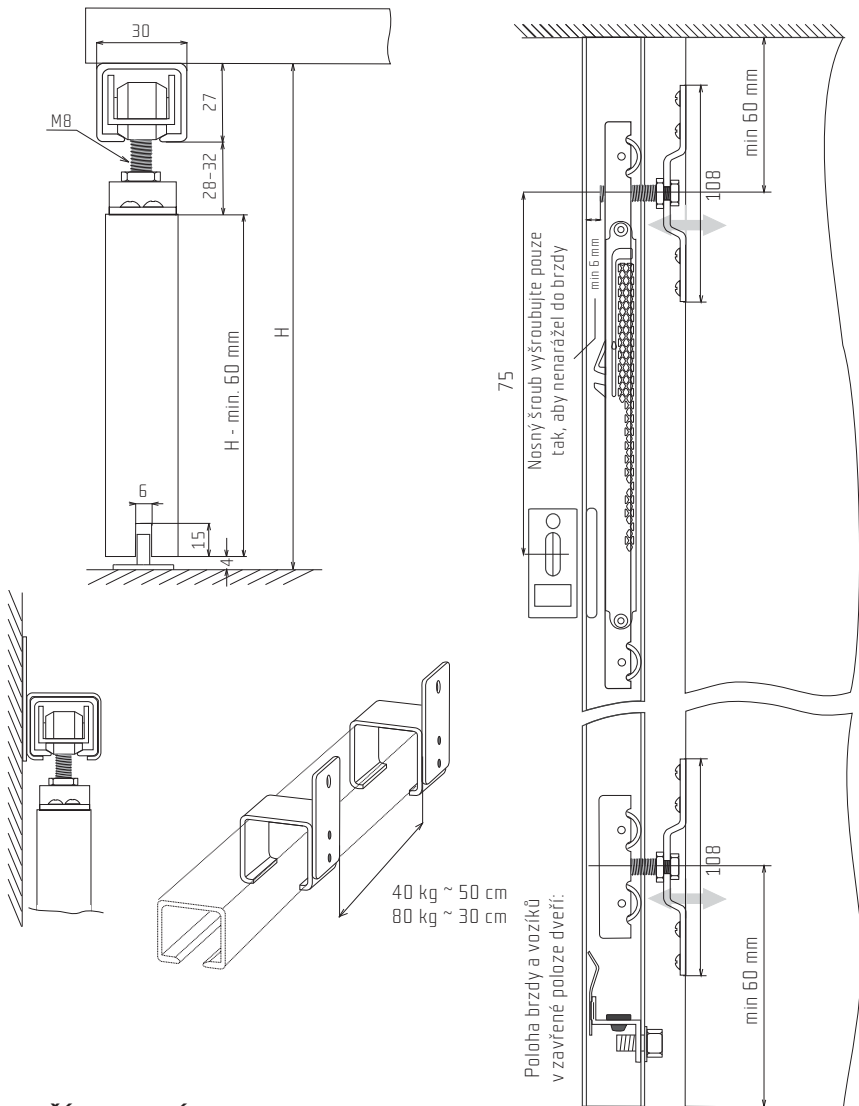

## SOUČÁSTI SYSTÉMU:

Brzda S40/S80

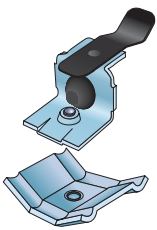

Plastové vodítko

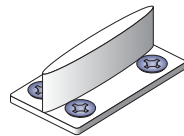

Stěnová příchytka

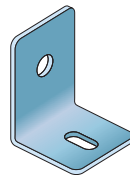

Sada S80SC

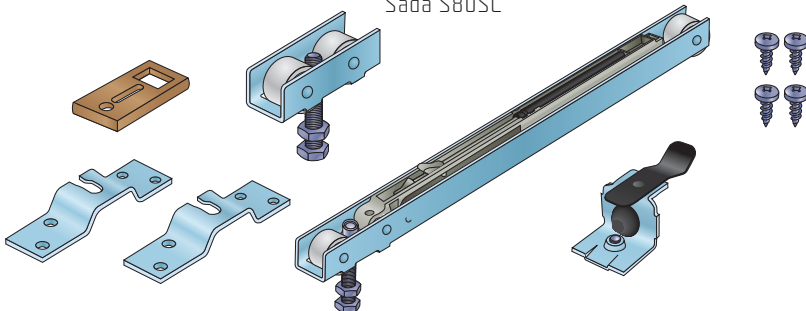

## S80

Kování pro interiérové posuvné dveře.

Přednosti systému:

- masivní vozíky
- hmotnost dveří je rozložena celkem na čtyři ložisková kolečka
- integrovaná brzda s dorazem
- seřiditelné spodní vodítko

## S80SC

Kování pro interiérové dveře. Varianta kování S80 s plynulým dotahem dveří.

# S100

PRO INTERIÉROVÉ  
DVEŘE

Montáž horního vozíku

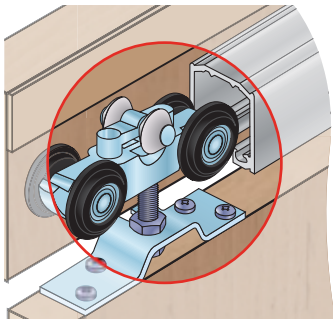

Brzda s tlumičem

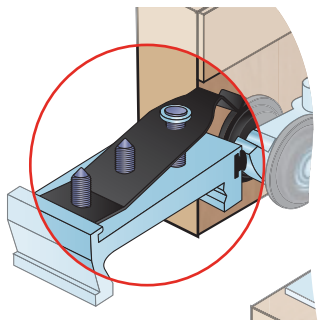

Montáž spodního kluzáku

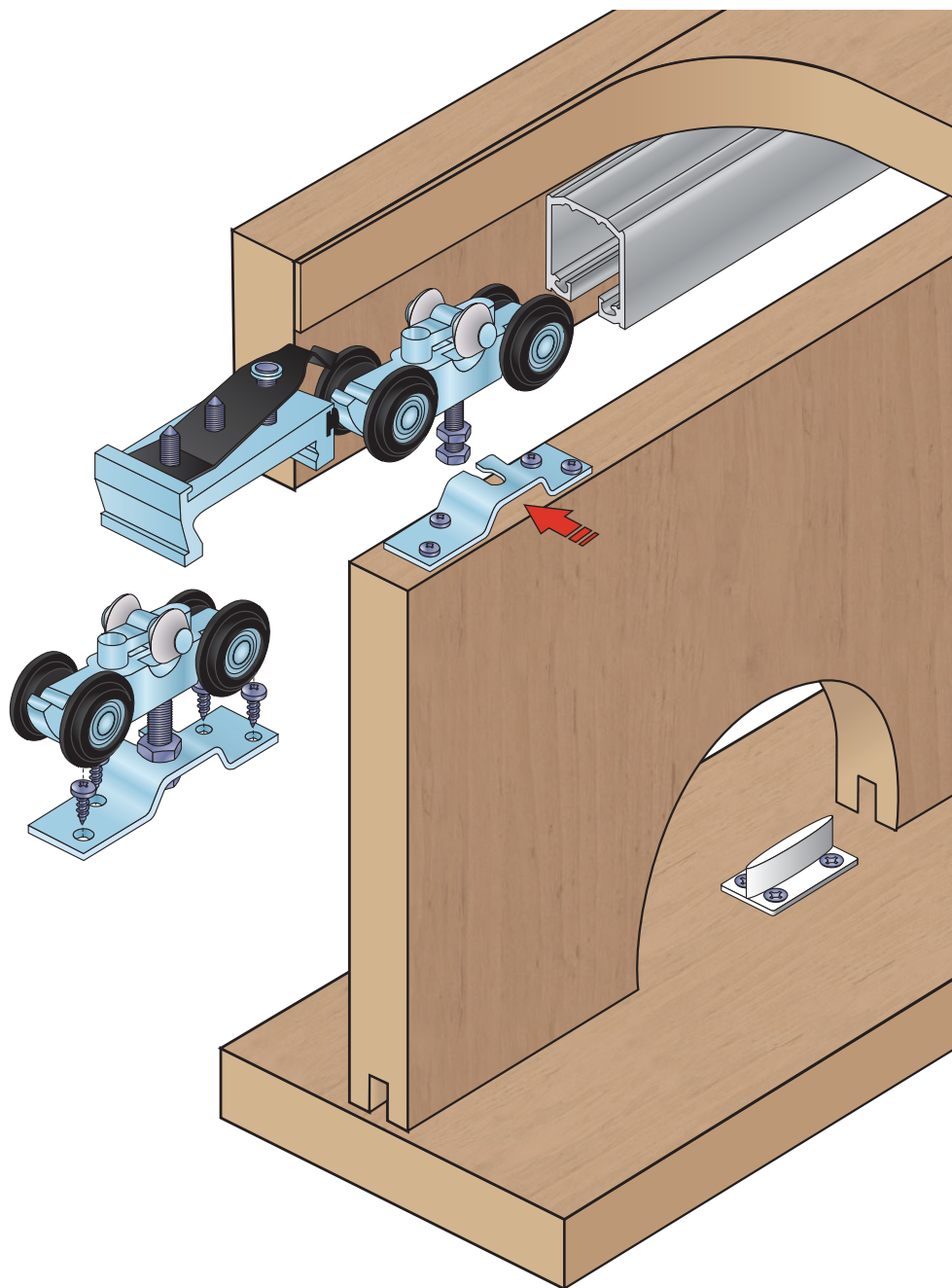
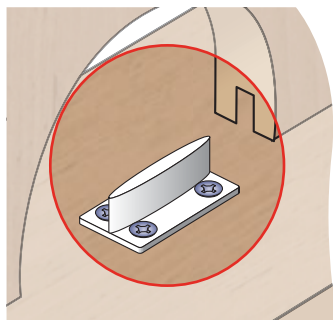

## SOUČÁSTI SYSTÉMU:

Sada S100

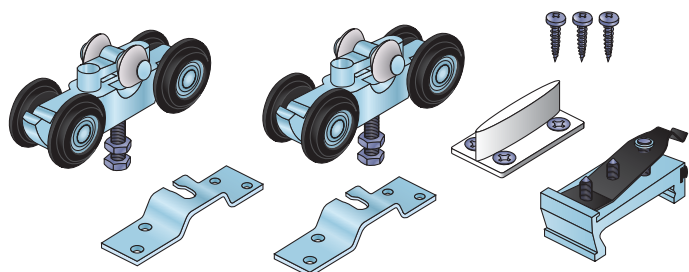

Profil S100

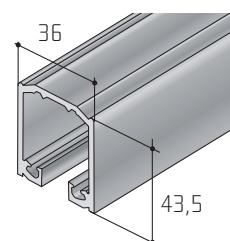





100 kg



kuličkové  
ložisko



min.  
18 mm



horní  
vedení

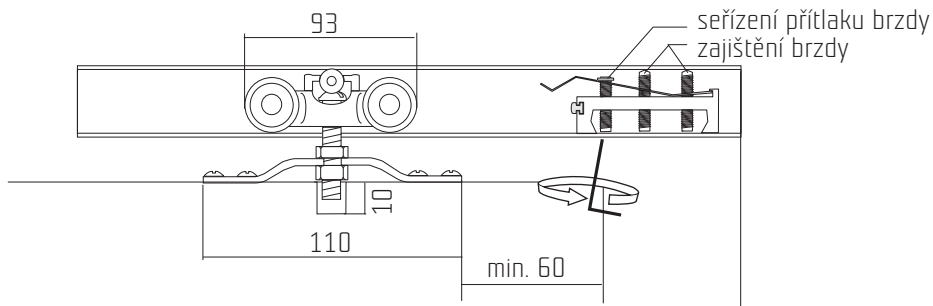
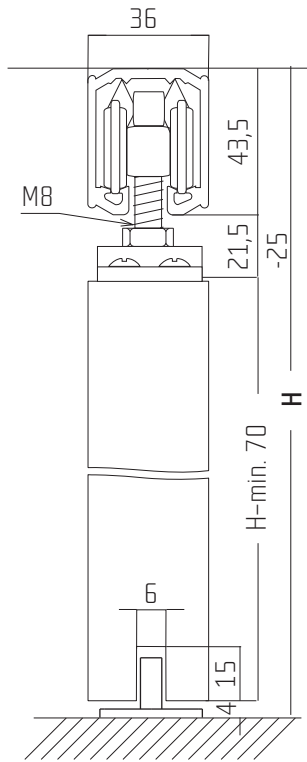

## S100

Kování SALU S100 je vyvrcholením naší nabídky.

System má tyto hlavní přednosti:

- tichý chod díky protiprachovému tvaru vodicí lišty a vyrovnávacím kladkám v horní části vozíků
- extrémně masivní konstrukce
- aretační brzdy se seřiditelným přtlakem

## 1.

Systém dveřního dovírání je určen pro naše kování S60/60N a dále pro rámový systém S55 a S65. Podrobný montážní návod je součástí balení.

## 2.

Dveřní dovírač má umístěn dovírací mechanismus před integrovaným horním vozíkem. Tím je na nejvyšší možnou míru zaručeno výškové seřízení dveří, protože dovírací mechanismus zabírá minimální prostor nad posuvnými dveřmi.

## 3.

Dveřní dovírač lze montovat na levou i pravou stranu dveří. Jeho konstrukce je dostatečně robustní, aby vydržela i prudší zavírání dveří.

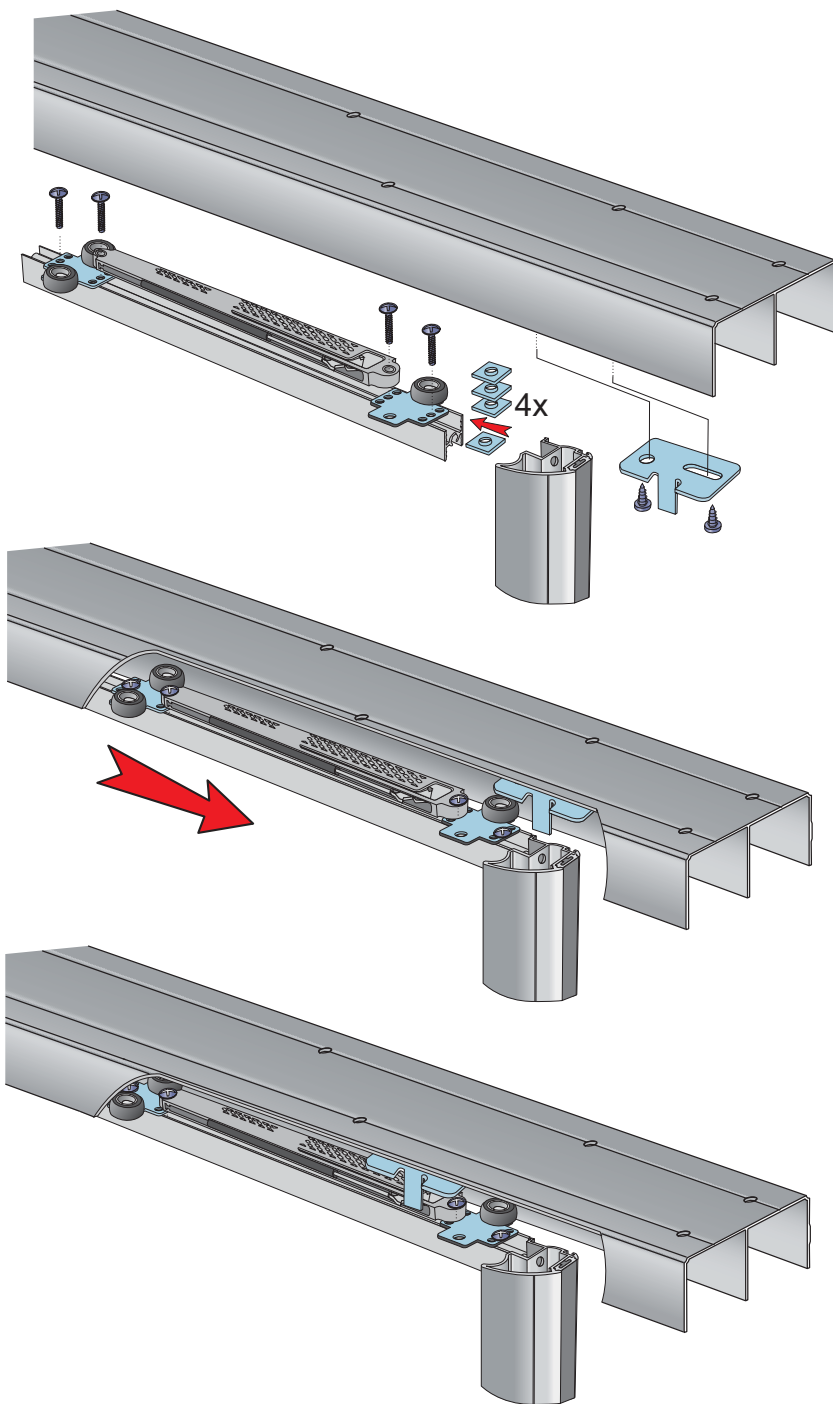

### SOUČÁSTI SYSTÉMU:

Softclose S55

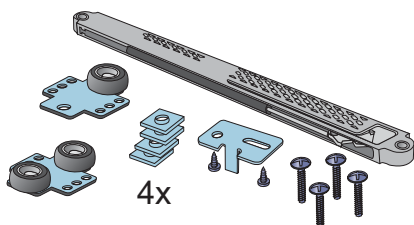

Softclose S60/S60N

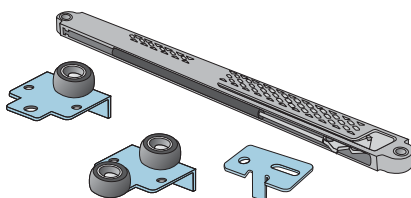

Softclose S65

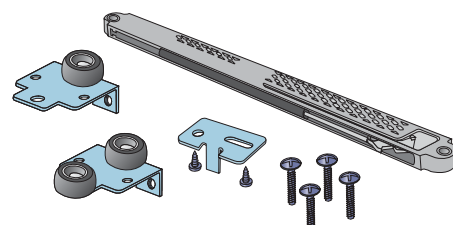

# HLINÍKOVÉ NÁBYTKOVÉ RÁMEČKY

A

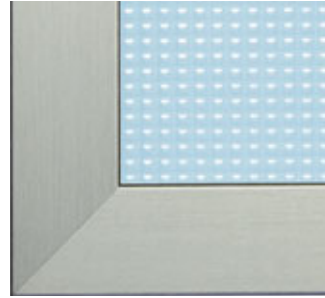
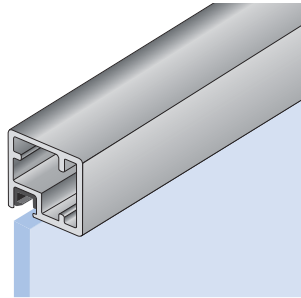
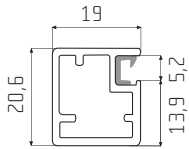

B

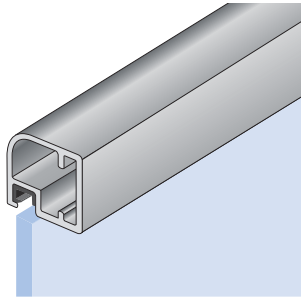
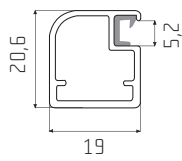

C

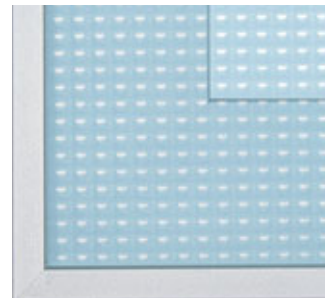
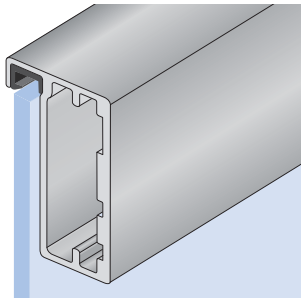
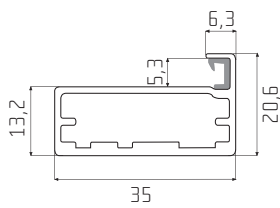

D

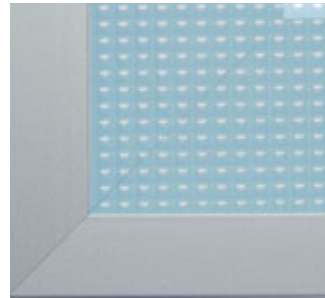
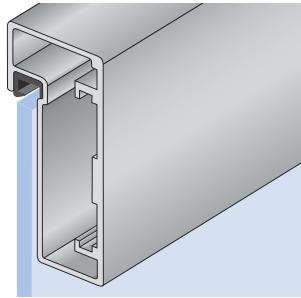
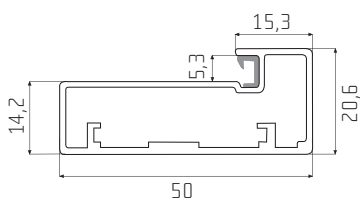

D1

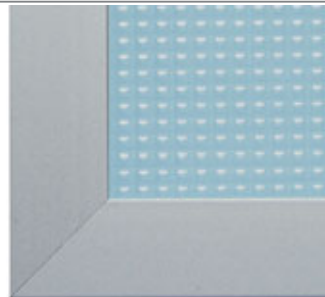
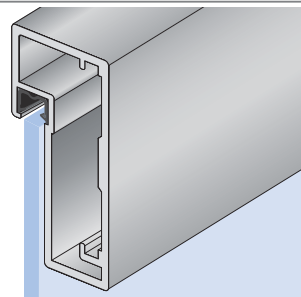
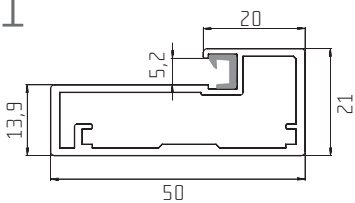

E

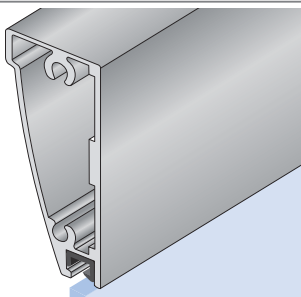
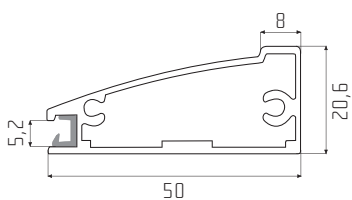

# HLINÍKOVÉ NÁBYTKOVÉ RÁMEČKY

F

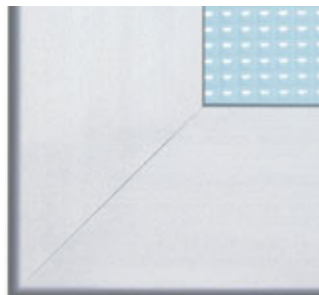
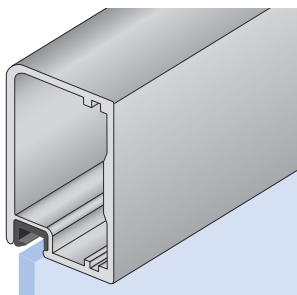
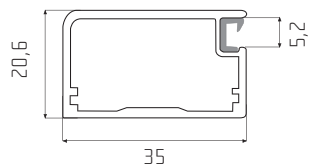

-  - stříbrný elox
-  - nerez světlý
-  - nerez tmavý

F1

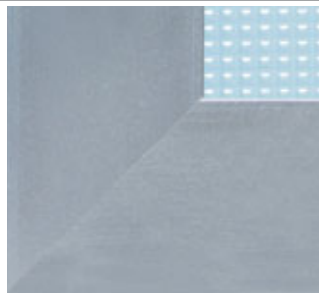
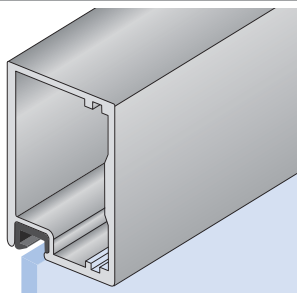
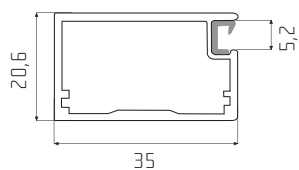

-  - stříbrný elox
-  - nerez světlý
-  - nerez tmavý
-  - chrom

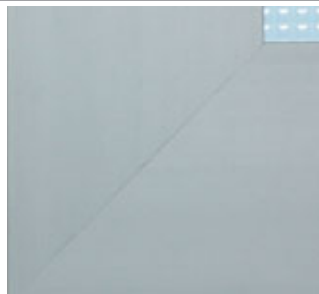
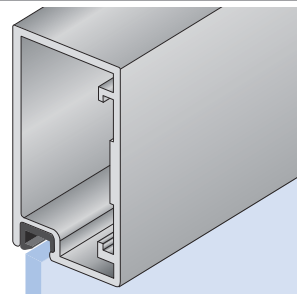
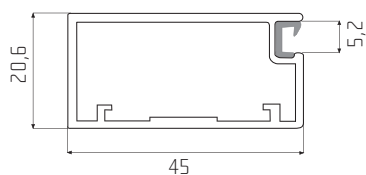

G



-  - stříbrný elox
-  - nerez světlý
-  - nerez tmavý

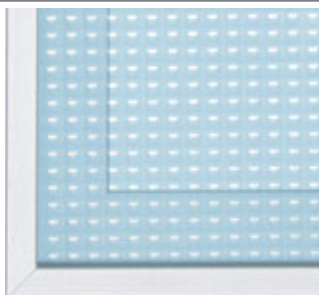
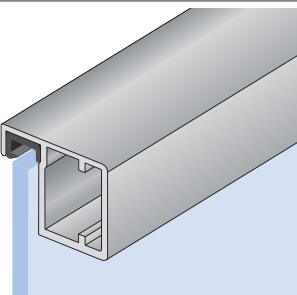
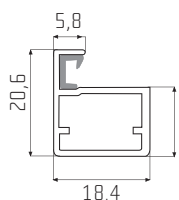

H

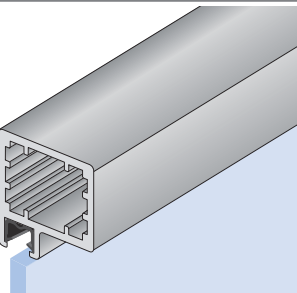
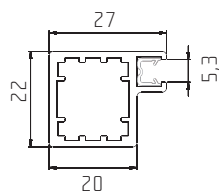

-  - stříbrný elox
-  - nerez světlý
-  - nerez tmavý

I



-  - stříbrný elox
-  - nerez světlý
-  - nerez tmavý

J

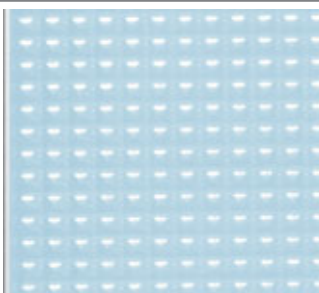
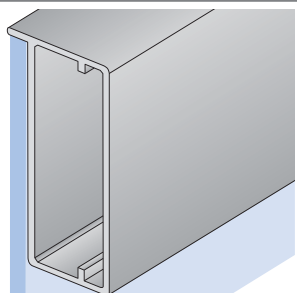
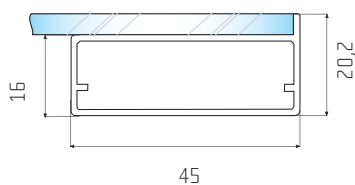

-  - stříbrný elox
-  - nerez světlý

## K

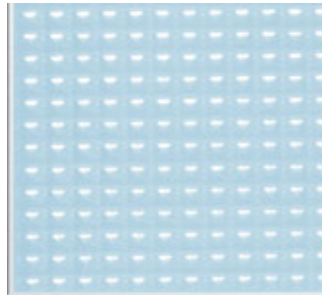
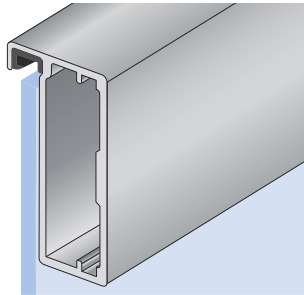
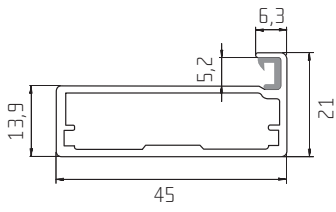

-  - stříbrný elox
-  - nerez světlý
-  - nerez tmavý

## M

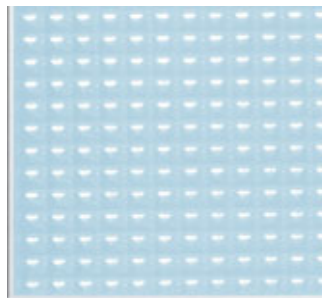
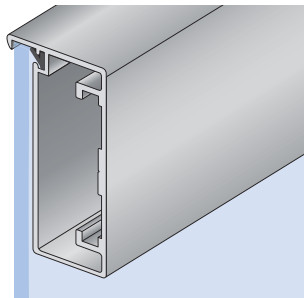
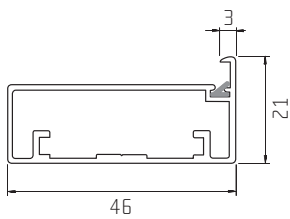

-  - stříbrný elox
-  - chrom

## PŘÍČKY

Příčka pro profily A a B

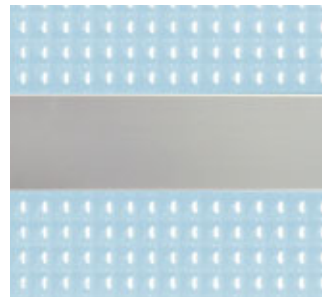
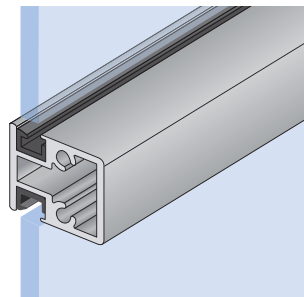
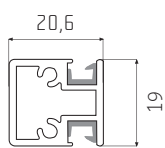

-  - stříbrný elox
-  - nerez světlý
-  - nerez tmavý

Příčka pro profil D

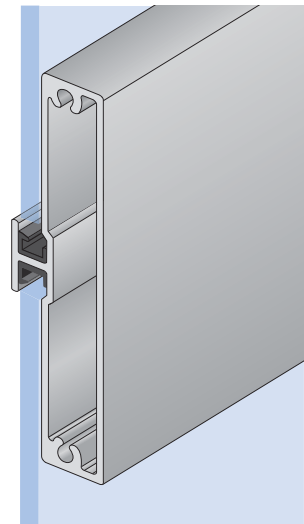
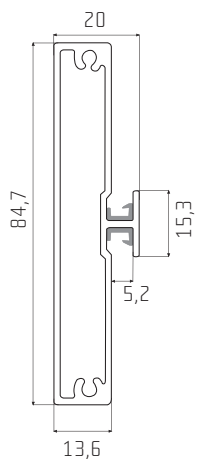

-  - stříbrný elox

# HLINÍKOVÉ NÁBYTKOVÉ RÁMEČKY



## Způsob dodání:

Hliníkové rámy jsou dodávány většinou v demontovaném stavu. Na požádání jsme schopni dodat rámy zasklené. Rámy jsou vyráběny dle specifikace zákazníka a prolibovolný typ závěsů.

profil	rozměr skla	spec. závěsy	mini závěsy	závěsy prům. 35 mm
A	- 30 mm	ANO	NE	NE
B	- 30 mm	ANO	NE	NE
C	- 6 mm	NE	ANO	NE
D	- 24 mm	NE	ANO	ANO
D1	- 29 mm	NE	ANO	ANO
E	- 93 mm	NE	ANO	ANO
F	- 62 mm	NE	ANO	NE
F1	- 62 mm	NE	ANO	NE
G	- 82 mm	NE	ANO	ANO
H	- 6 mm	ANO	NE	NE
I	- 43 mm	ANO	NE	NE
J	- 2,5 mm	NE	ANO	ANO
K	- 6 mm	NE	ANO	ANO
M	- 3 mm	NE	ANO	ANO

Rozměr skla: v tabulce uvedený rozměr je nutno odečíst od výšky i od šířky rámu. Např. rám z profilu B o rozměrech 396 x 600 mm bude mít rozměr výplně 366 x 570 mm.

Speciální závěsy jsou myšleny závěsy určené pouze pro rámy z profilů o průřezu cca 20 x 20 mm.

Rozměry skla pro příčky:

Příčka A, B, F a G:

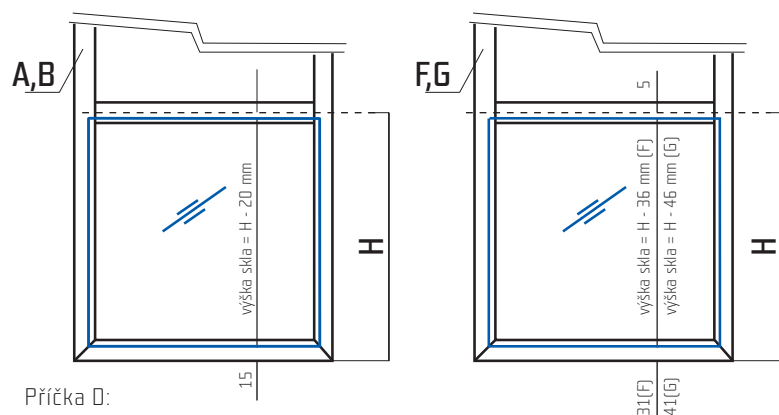

Příčka D:

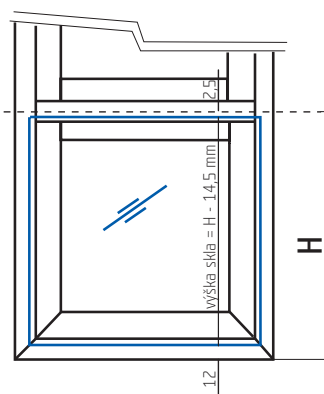

## NK1 – kruhová

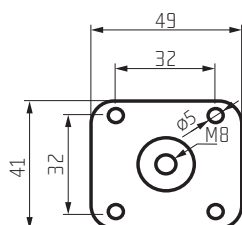
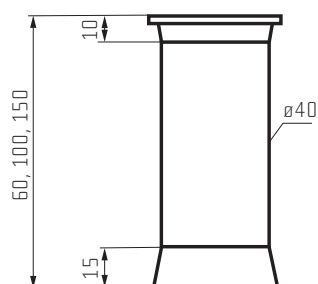

- stříbrný elox

## NK2 – kruhová

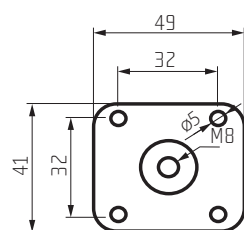
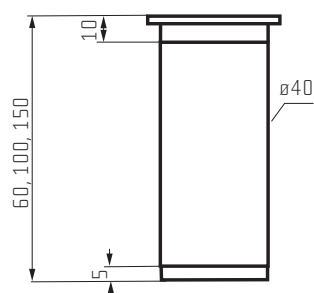

- stříbrný elox

## NK2 – čtvercová

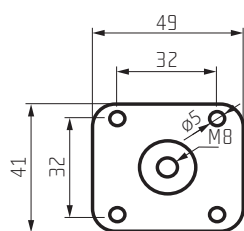
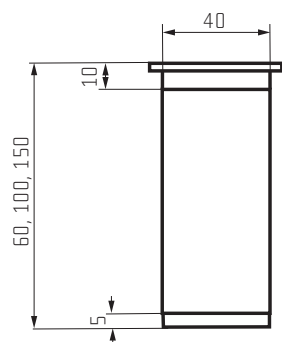

- stříbrný elox

## NK1 – čtvercová

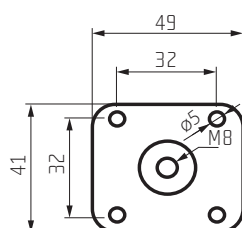
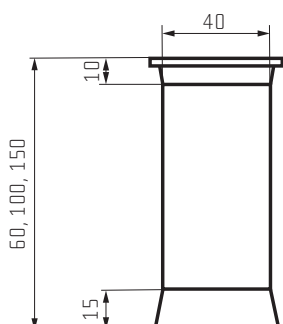

- stříbrný elox

# DNA S-LED MINI

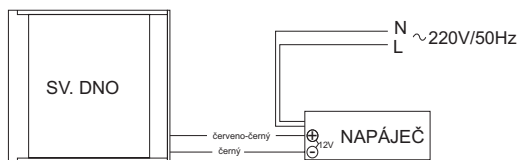
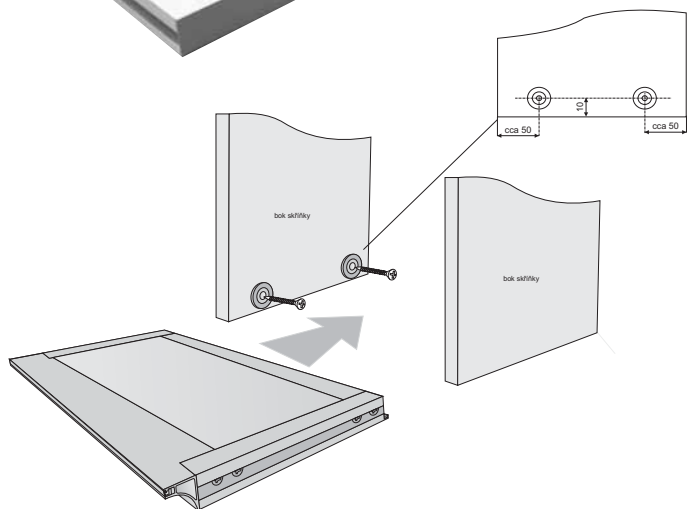

## Montážní návod:

- na stěny skříňky našroubujte úchyty světelného dna dle nákresu
- na úchyty nasuňte světelné dno
- dno se zadní strany zajistěte nasunutím zad z MDF 3 mm
- zapojte přívod el. proudu dle schématu, zapojení přívodu napětí do napáječe svěřte odborníkovi dle návodu k napáječi

Světelná dna S-Led mini se vyrábějí v tloušťce profilu 21 mm, což se blíží skutečné tloušťce klasického dřevěného „dna“ skříňky. Oproti zářivkové verzi nabízí mnohem větší životnost světelného zdroje a úsporu energie. Vyrábí se v bezúchytkové variantě i v klasické variantě s rovným čelem.

Verze A



Verze B

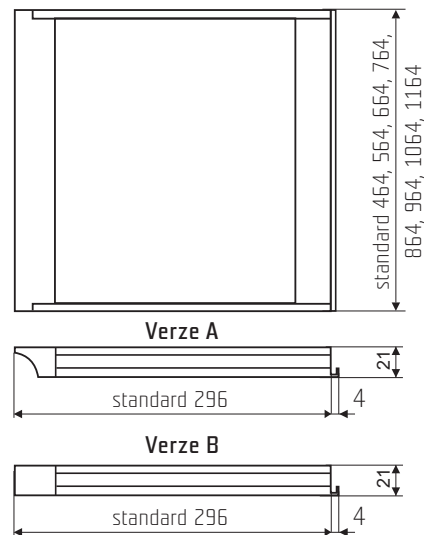

Příklad označení: S-LED mini 564/298 Bil. - šířka dna 564, hloubka 296 plus drážka na záda skříňky, rovné čelo dna, pásek LED i v zadním profilu dna.

	typ I.	typ II.
led 5 x 5mm, 3200K (tříčipové LED diody)	LED v předním profilu a do skla	LED v předním profilu, do skla a vzadu
označení	odběr W	odběr W
S-Led mini 564/296	12	20
S-Led mini 664/296	15	24
S-Led mini 764/296	17	28
S-Led mini 864/296	19	31
S-Led mini 964/296	22	35
S-Led mini 1064/296	24	39
S-Led mini 1164/296	26	43

\*standardní rozměry, možnost výroby nestandardních rozměrů

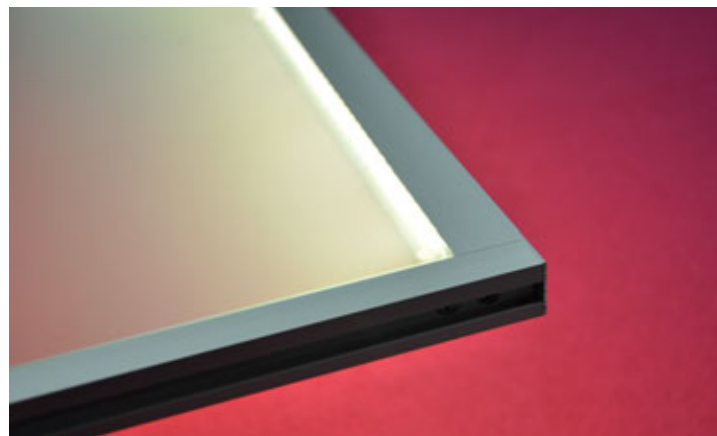



Světelné police:  
příklad označení: SL1000/220

hloubka  
délka

označení	příkon
SL600/220	12 W
SL800/220	20 W
SL900/220	2 x 8 W
SL1000/220	2 x 12 W
SL1200/220	2 x 16 W
SL600/300	12 W
SL800/300	20 W
SL900/300	2 x 8 W
SL1000/300	2 x 12 W
SL1200/300	2 x 16 W

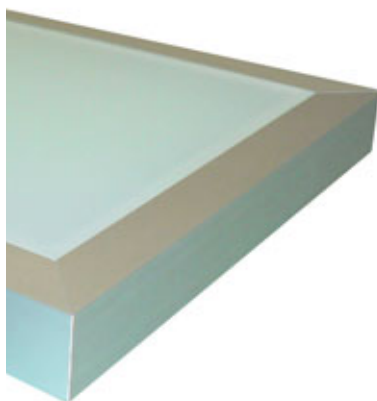

Světelná dna:  
příklad označení: SL564/296

hloubka  
délka

označení	příkon
SL564/296	12 W
SL764/296	20 W
SL864/296	2 x 8 W
SL964/296	2 x 12 W
SL1164/296	2 x 16 W



Možnost přizpůsobení hloubky dle požadavku zákazníka.



Vhodný zdroj osvětlení je nezbytnou součástí dodávky většiny moderních interiérů, především kuchyňských linek. Linie nejčistšího designu, propagovaná naší firmou, nás vedla k vytvoření osvětlení, které je zakomponováno buď do polic montovaných na stěnu nebo přímo do dna horních kuchyňských skříněk. Tím odpadá jakýkoliv rušivý prvek v podobě typického osvětlovacího tělesa a jediné, co uživatel pocítí, je teplé přívětivé světlo.

Police a dna jsou vyrobeny z eloxovaných hliníkových profilů a osazeny mléčným sklem. Police i dna se vyrábějí v typizovaných rozměrech, ale jsme schopni vyjít vstříc i individuálním přáním zákazníků. Systém „neviditelných“ rohových spojů je výlučným průmyslovým vlastnictvím naší firmy.



# HLINÍKOVÉ NÁBYTKOVÉ PODNOŽE



4 typy profilů:

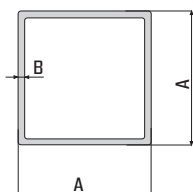

A  
30 mm  
45 mm  
80 mm

B  
2 mm  
2 mm  
2 mm

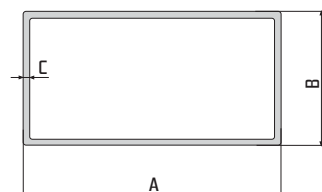

A  
80 mm

B  
40 mm

C  
2 mm

Příklad rohového spoje:

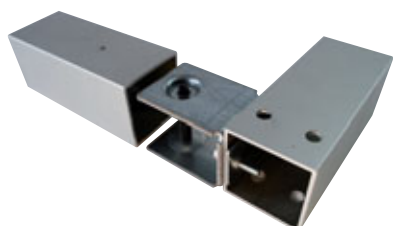

Zátky, zátky s rektifikací:

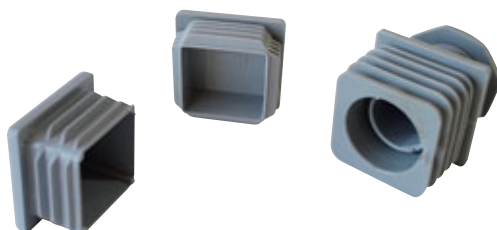

Spojka:

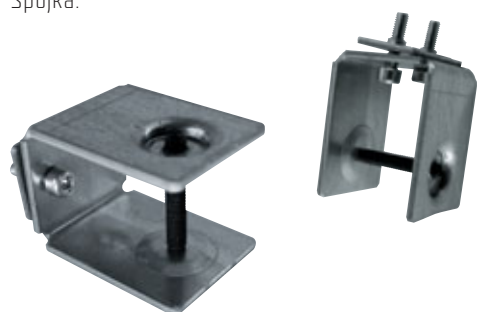

Kolečko:



System pro výrobu stolů, podstavců pod skříně, kuchyně atp.



# MADLA A ÚCHYTKOVÉ PROFILY

UKW 1

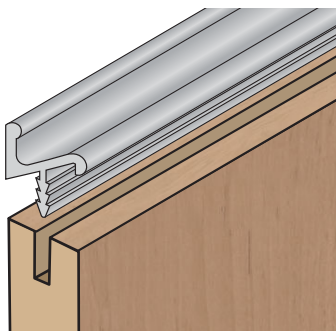
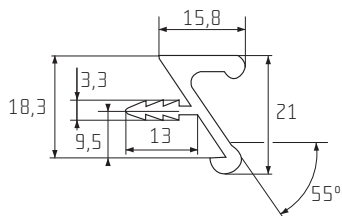

- stříbrný elox

UKW 2

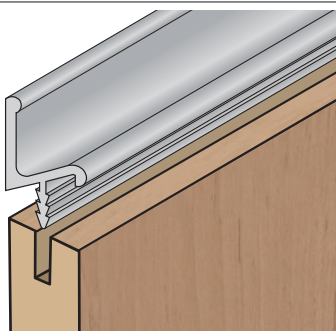
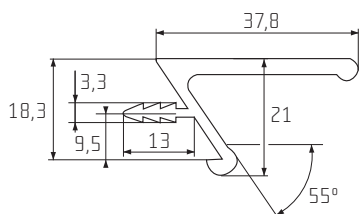

- stříbrný elox

UKW 4

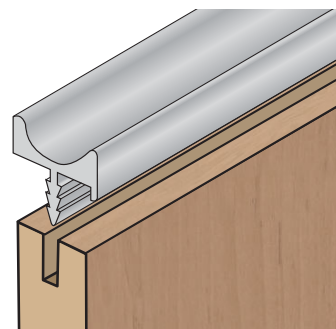
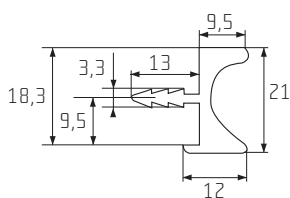

- stříbrný elox

UK 5

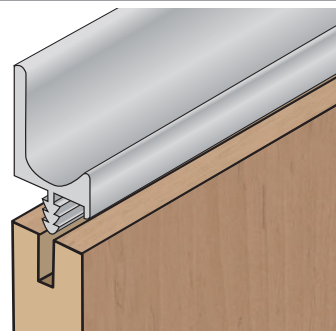
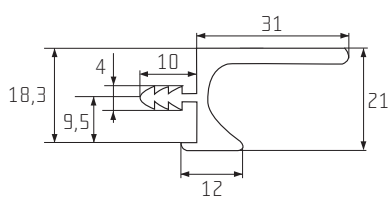

- stříbrný elox

UK 7

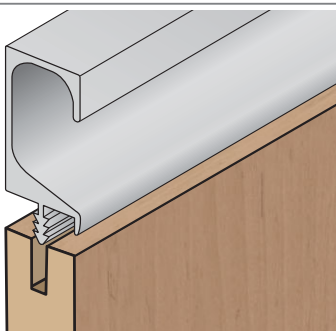
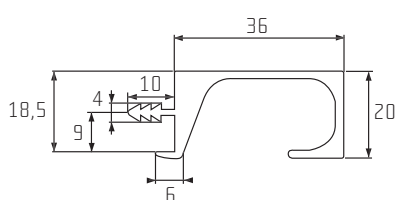

- stříbrný elox

Narážecí hrana 01

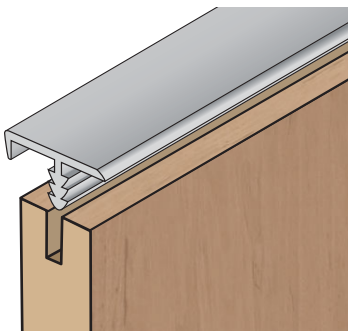
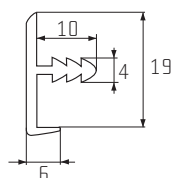

- stříbrný elox

Narážecí hrana s madlem 02

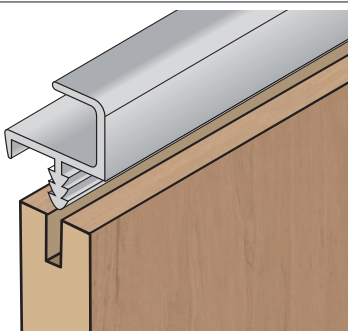
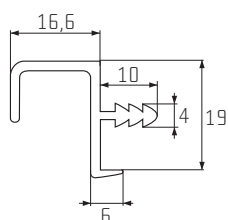

- stříbrný elox

Narážecí hrana pro tl. desky 28 mm

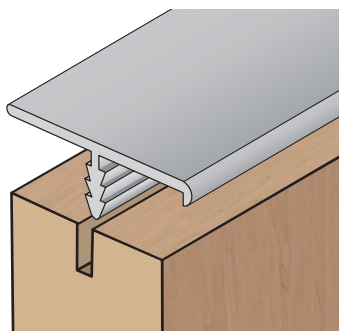
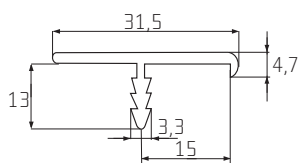

- stříbrný elox

Narážecí hrana pro tl. desky 38 mm

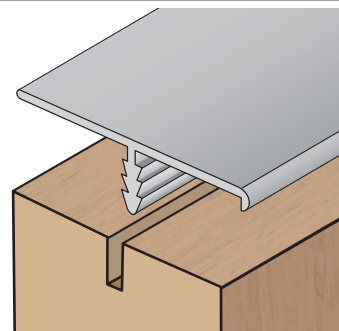
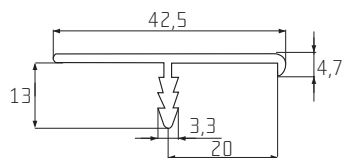

- stříbrný elox

Profil U pro tl. desky 18 mm

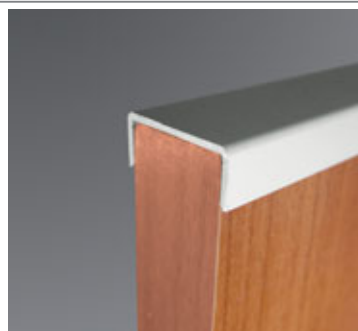
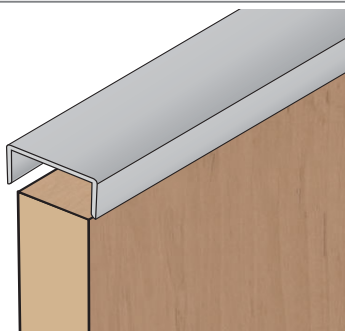
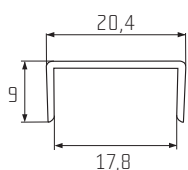

- stříbrný elox

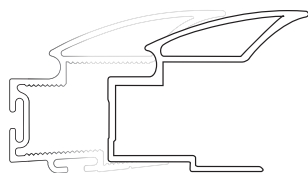

# MADLA A ÚCHYTKOVÉ PROFILY

S04/S04N

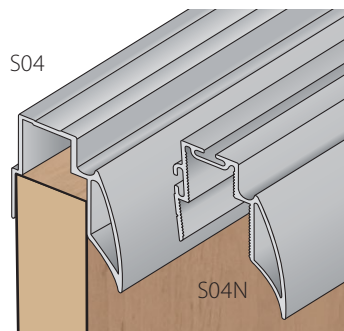

S04N S04



-  - stříbrný elox
-  - světlý bronz
-  - tmavý bronz

S08

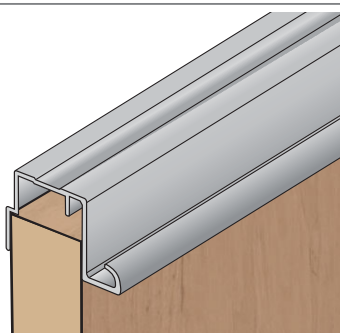
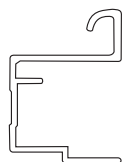

-  - stříbrný elox
-  - světlý bronz
-  - tmavý bronz

S09

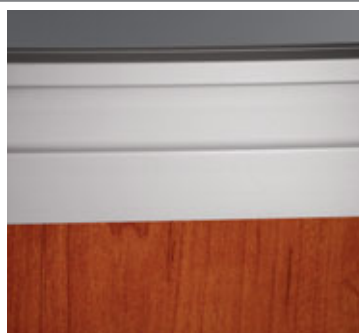
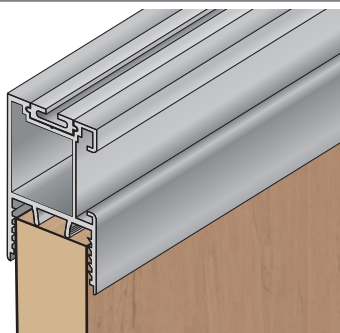
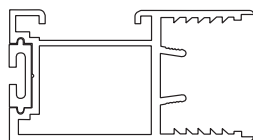

-  - stříbrný elox
-  - světlý bronz
-  - tmavý bronz

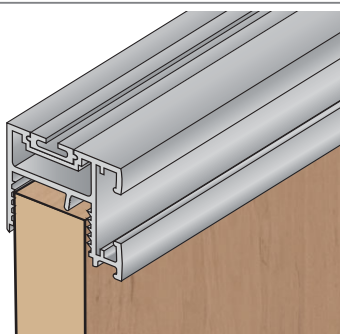
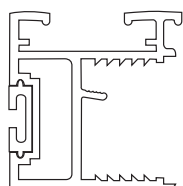

S10

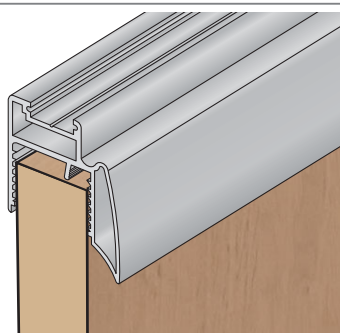
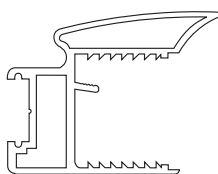

-  - stříbrný elox
-  - světlý bronz
-  - tmavý bronz

S11



-  - stříbrný elox
-  - světlý bronz
-  - tmavý bronz

S12

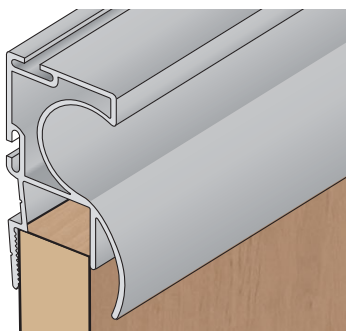
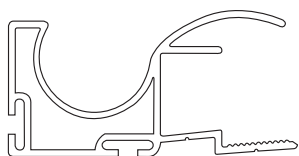

- stříbrný elox
- světlý bronz
- tmavý bronz

S13

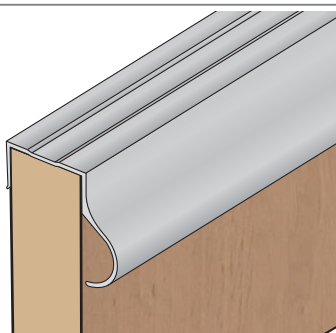
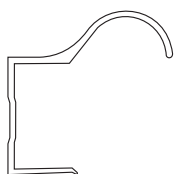

- stříbrný elox
- světlý bronz
- tmavý bronz

S14

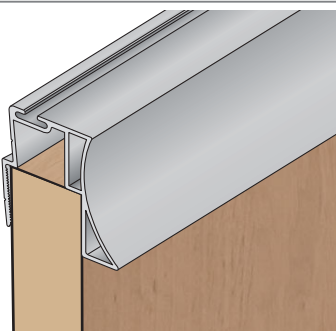
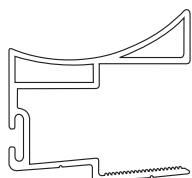

- stříbrný elox
- světlý bronz
- tmavý bronz

S07

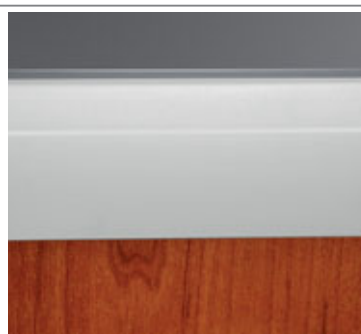
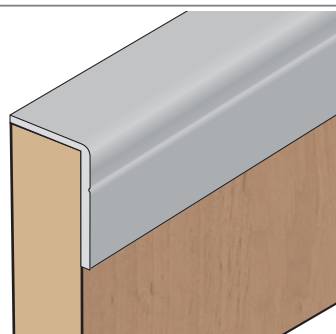

- stříbrný elox
- světlý bronz
- tmavý bronz

Profil T

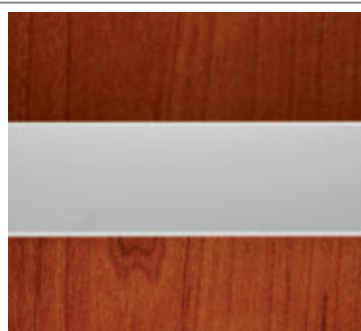
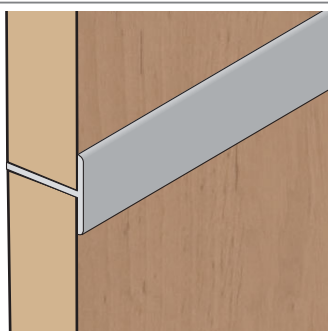
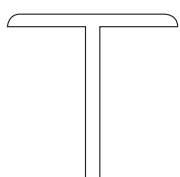

- stříbrný elox
- světlý bronz
- tmavý bronz

# MADLA A ÚCHYTKOVÉ PROFILY

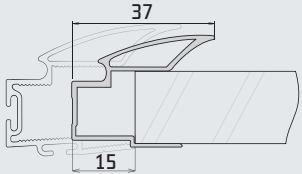
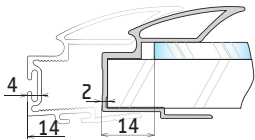
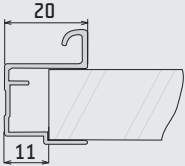
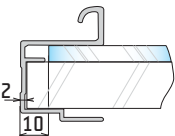
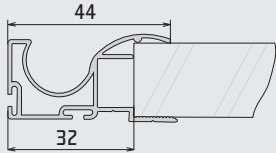
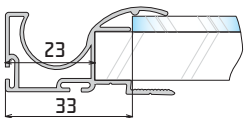
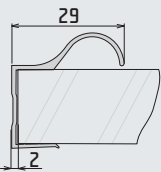
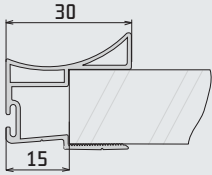
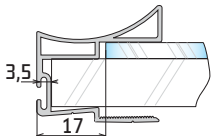
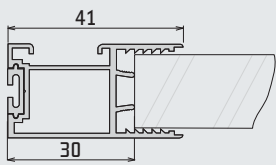
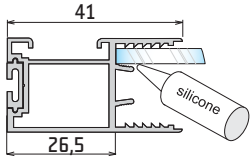
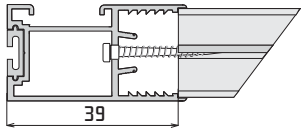
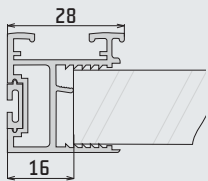
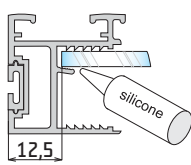
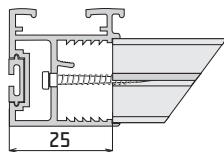
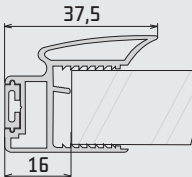
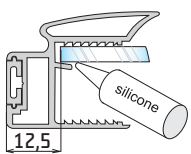
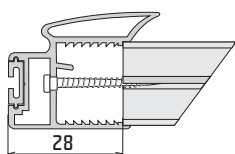
	Montáž na lamino tl. 18 mm	Montáž na lamino tl. 12 mm a zrcadlo tl. 4 mm	Montáž se sklem tl. 4 mm
S04/S04N			X
S08			X
S12			X
S13		X	X
S14			X
	Montáž na lamino tl. 18 mm	Montáž se sklem tl. 4 mm	Montáž příček
S09			
S10			
S11			



Montáž na lamino tl. 18 mm

Montáž na lamino tl. 12 mm  
a zrcadlo tl. 4 mm

Montáž se sklem  
tl. 4 mm

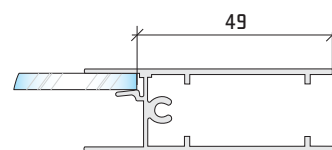
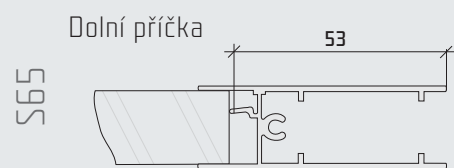
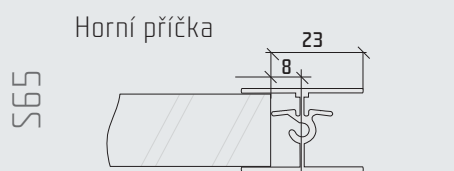

Montáž na lamino tl. 10 mm

Montáž na sklo tl. 4 mm

Montáž příček

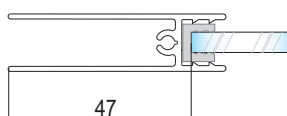
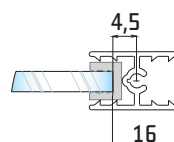
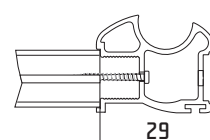
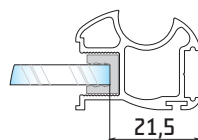
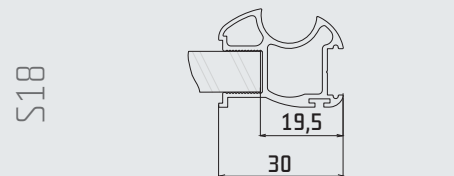
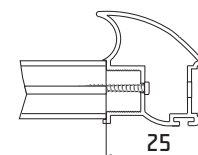
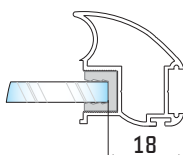
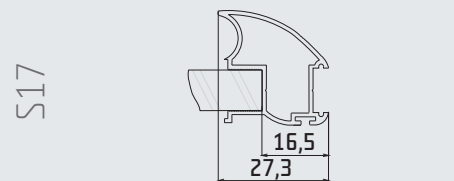
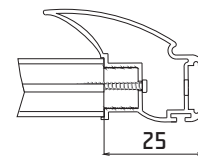
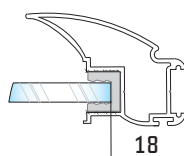
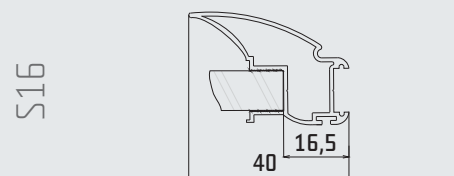
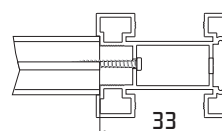
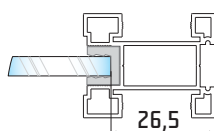
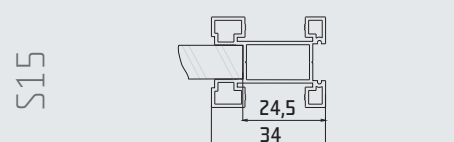

# SKLENĚNÉ VÝPLNĚ



## Klasická



Zrcadlo (stříbrné, bronz)



Číré

## Lakovaná skla



Lacomat White

## Lakovaná skla – Lacobel

				
Pure White Ref 9003	Soft White Ref 9010	Pearl White Ref 1013	Light Beige Ref 1015	Classic Beige Ref 1014
				
Classic Grey Ref 7035	Metal Grey Ref 9006	Metal Blue Ref 1435	Pastel Blue Ref 1603	Luminous Blue Ref 5002
				
Pastel Green Ref 1604	Luminous Green Ref 1164	Jungle Green Ref 0667	Starlight Black Ref 0337	Classic Black Ref 9005
				
Classic Orange Ref 2001	Luminous Red Ref 1586	Fuchsia Ref 4006	Dark Red Ref 3004	Dark Brown Ref 8017
				
Light Brown Ref 1236	Rich Aluminium Ref 9007	Metal Taupe Ref 0627	Rich Gold Ref 0327	Rich Copper Ref 0128

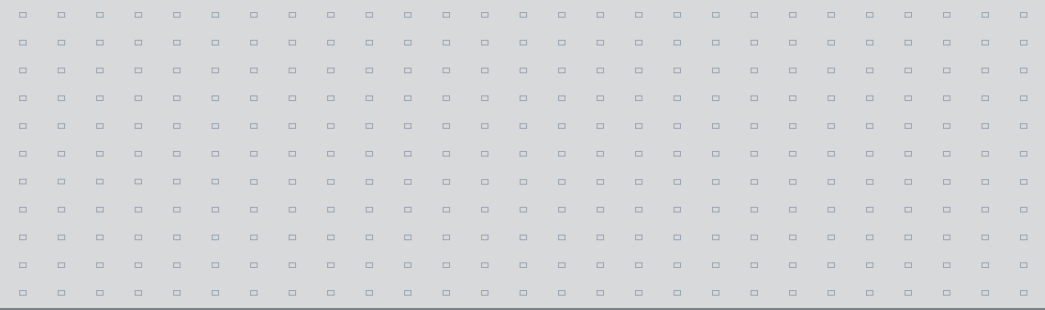

## Ornamentální



Mastercarre



Krizet

## Bezpečnostní



Connex čirý



Screen



Flutes matovaný



Connex mléčný

## Satinovaná



Matelux White



Matelux Green



Matelux Blue



Matelux Grey



Matelux Bronze



SALU Systems, s.r.o., Žihla 992, 739 91 Jablunkov  
tel./fax: +420 558 326 377, tel.: +420 558 340 283, info@salu.cz  
[www.salu.cz](http://www.salu.cz)